



# DAF SERİSİ

## DAF SERIES

AKIM BASKILI FREN SİSTEMLERİ  
CURRENT SUPPLY BRAKES



Durdurmak İçin / For Brake Solutions

DAF

SERİSİ / SERIES

## AKIM BASKILI FREN SİSTEMLERİ CURRENT SUPPLY BRAKES

### Uygulama Alanları

- Döner Kapı
- Dikiş Makinesi
- Tekstil Makinaları
- Matbaa Makinaları
- Otomasyon Teknolojileri

### Areas of Application

- Revolving Door
- Sewing Machine
- Textile Machinery
- Offset Printing Machine
- Automation Technology



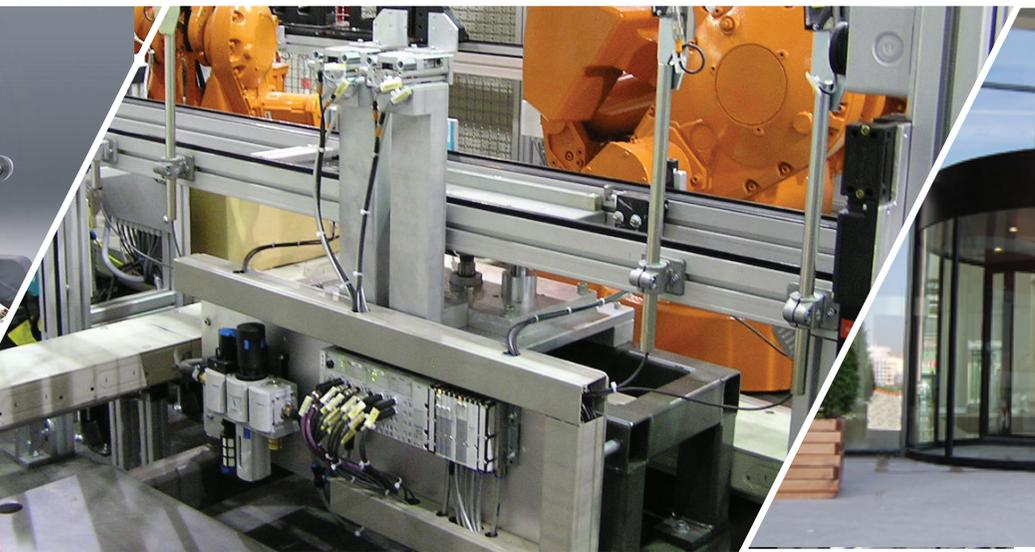

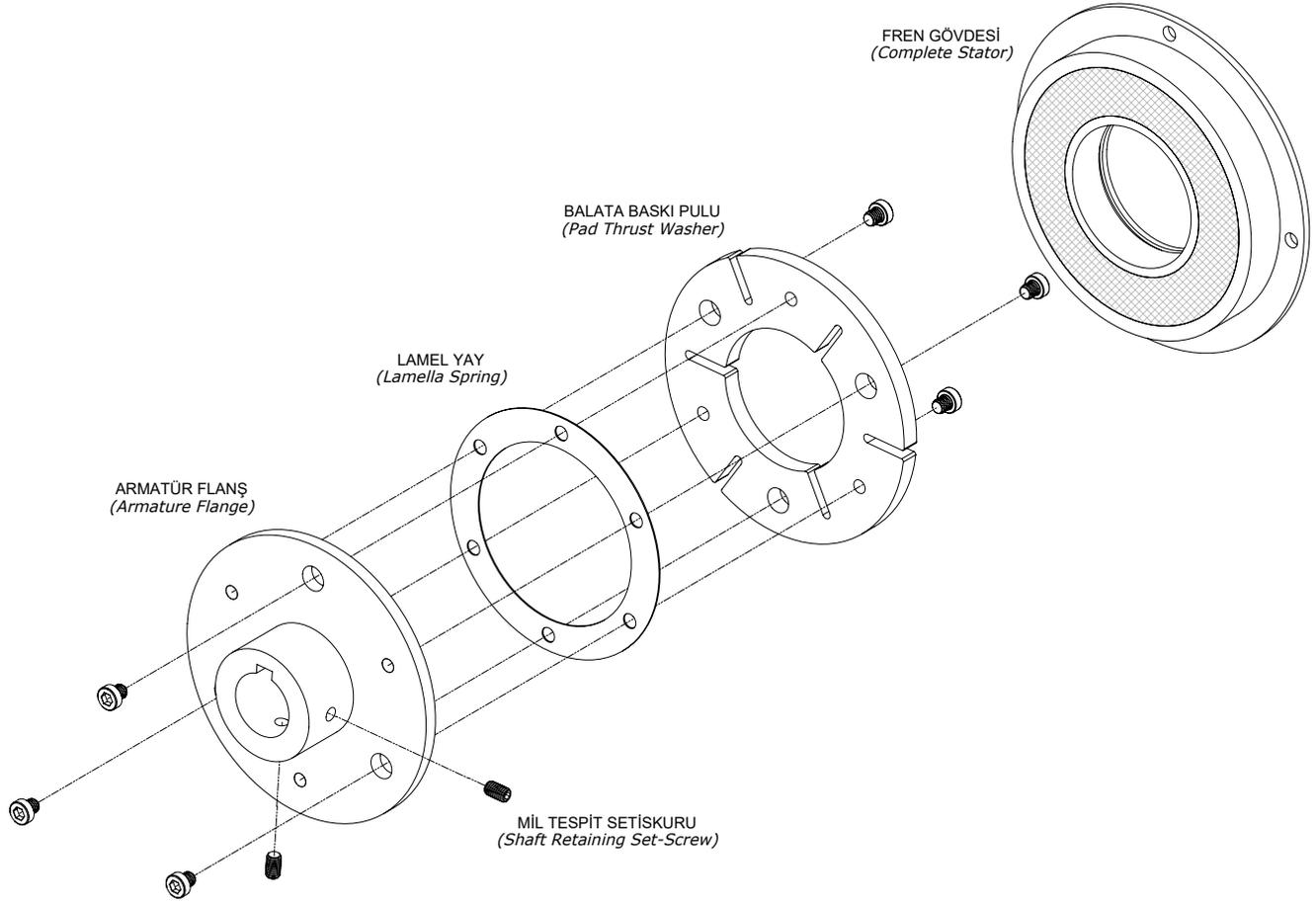

- Frenlerde ses düzeyi <70 Db altındadır.
- Farklı büyüklüklerdeki motorlar için yüksek frenleme torku sağlanmıştır.
- Elektromagnetik sargı ısıya dayanıklı malzemeden hazırlanan bobin kalıbı üzerine sarılıp, Epoksi ile muhafaza edilmektedir. (bobin izolasyon sınıfı H-180°).
- Tüm mekanik parçalar elektrolize edilip korozyona karşı koruma sağlanmıştır.
- Frenlerde uzun ömürlü, sürtünme katsayısı yüksek asbestsiz balatalar kullanılmaktadır.
- Fren bobin gövdeleri GGG 42 sfero dökümden imal edilip histerisiz kayıpları minimuma indirgenmiştir.
- Frenler her çeşit motorda ara bağlantı flanşı değiştirerek kullanılabilecek şekilde tasarlanmıştır.
- Frenler her çeşit pozisyonda çalışabilirler.
- Mekanik parçaların tümünü CNC tezgahlarında işlenmektedir.
- Tüm frenler microswitch, proxyswitch ve encoder montajına uygun olarak tasarlanmıştır.
- Frenler özel istekler dışında standart olarak 24 Vdc olarak üretilmektedir.
- Frenler DAF Serisinde 8 Nm 480 Nm torkları arasında üretilmektedir.

- Noise level is <70 Db for brakes.
- For motors of different sizes high braking, torque had been provided.
- Electromagnetic coils are enfolded to coil molds which are made of heatproof material and protected with epoxy. (coil insulation range is H-180°)
- All mechanical parts are electrolysed and protected against corrosion.
- In brakes Long-life high coefficient of friction and asbestos free brake pads are used
- Brake coil bodies are manufactured (rom GGG42 sphrocasting which reduces hysteresis losses to minimum.
- Brakes are designed to be used in all types of motors by changing intermediate connection flanges.
- Brakes can operate in every position.
- All mechanical parts are processed in CNC workbenches.
- All brakes are designed consistent to microswitch, proxyswitch and encoder assembly.
- Brakes are manufactured as 24 Vdc special requests.
- Brakes are manufactured as; in DAF models between BNm to 480 Nm torque levels.

- 1-Armatür Flanş
- 2-Mil Tespit Setiskuru
- 3-Lamel Yay
- 4-Balata Baskı Pulu
- 5-Fren Balatası
- 6-Fren Bobini
- 7-Fren Gövdesi
- 8-Bobin Besleme Kablosu
- 9-Balata Pulu Tespit Cıvatası

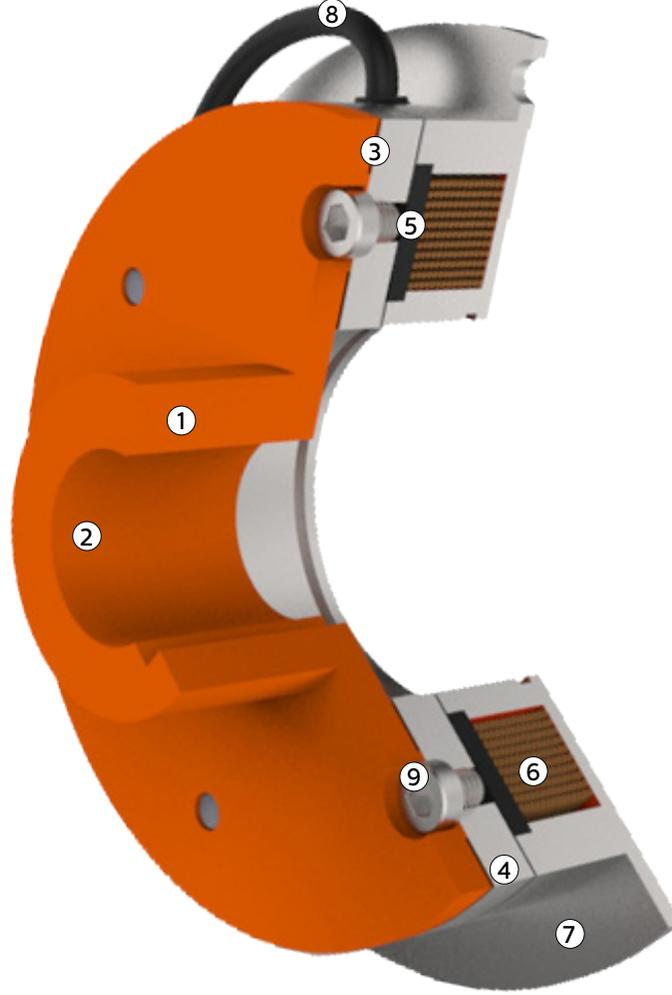

- Armature Flange -1
- Shaft Retaining Set-Screw -2
- Lamella Spring -3
- Pad Thrust Washer -4
- Brake Pad -5
- Brake Coil -6
- Brake Stator -7
- Coil Feeding Cable -8
- Thrust Washer Retaining Screw -9

Akım baskılı frenler genellikle çok sık durup hareket eden ve hassas durma gerektiren yerlerde uygulanan bir frenleme sistemidir.

Fren bobinine (24 Vdc ) akım uygulandığında fren bobin gövdesi (no:6) yüzeyinde oluşan manyetik alan aynı eksenindeki balata baskı flanşını kendine doğru çekerek frenlemeyi gerçekleştirir ve bu işlem gerilim uygulandığı, sürece devam eder.

Akım kesildiğinde balata baskı flanş (no:4) altında bulunan lamel yay (no:3) vasıtasıyla bobin gövdesi yüzeyinden ayrılır ve frenleme sonlanır.

Akım baskılı frenler genellikle dakikada 60 ile 100 defa açma kapama yapabilen sistemlerdir ve yay baskılı frenlerin çalışma sistemlerine göre tam tersi olarak çalışmaktadırlar. Akım baskılı frenler özel istek dışında genellikle 24 Vdc olarak imal edilirler.

Current-pressure brake systems are used usually where start/stop actions are frequent and accurate stopping needed.

When current (24 Vdc) is applied to the brake coil, the magnetic field formed on the brake coil body (no.6) performs braking by pulling the pad pressure flange which is on the same axis to itself, and the braking continues as long as the current applied.

When the current cut off, lamella spring (no.3) separates the pad pressure flange (no.4) from the coil body surface and braking process ends.

Current-pressure brakes can usually perform between 60 and 100 opening/closing actions per minute and their operating principles are the opposite of spring-pressure brakes. Current-pressure brakes are usually manufactured as 24 Vdc, except custom requests.

DAF

SERİSİ / SERIES

FREN MODELLERİ ve MONTAJ UYGULAMALARI  
Brake Models & Assembly Applications

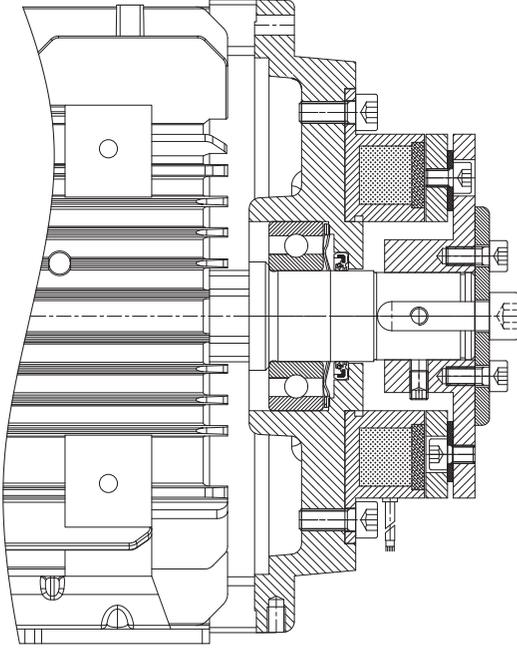

DAF-M1 TİP UYGULAMA / DAF-M1 Type Application

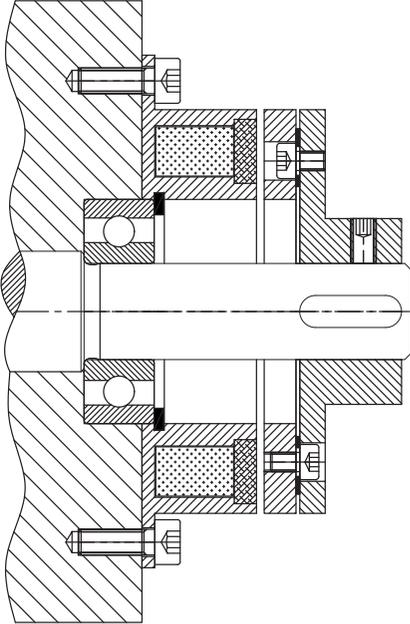

DAF-M2 TİP UYGULAMA / DAF-M2 Type Application



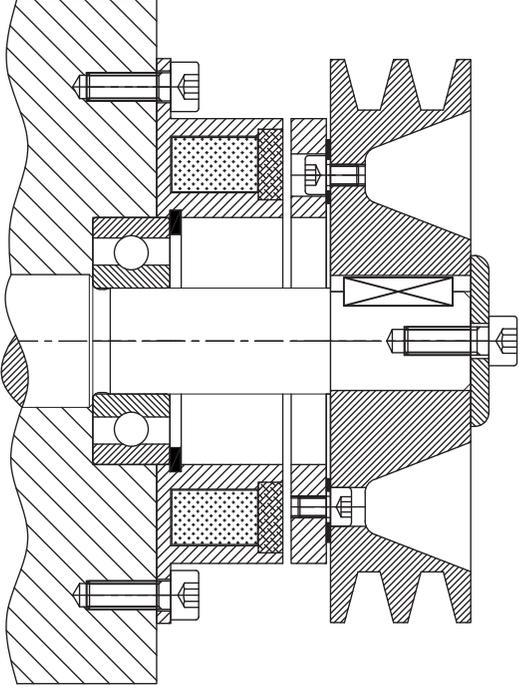

**DAF-M TİP UYGULAMA / DAF-M Type Application**



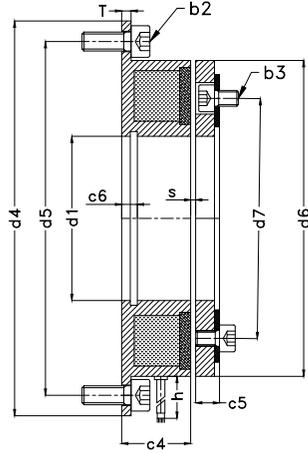
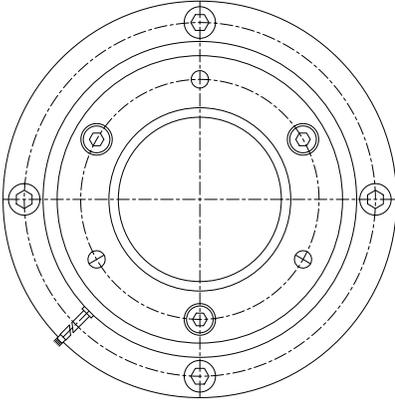

## Teknik Özellikler / Technical Specifications

Tip/Type	DAF-01	DAF-02	DAF-03	DAF-04	DAF-05	DAF-06	DAF-7
Nm	8	16	32	65	120	240	480
b2	4-M4	4-M5	4-M6	4-M6	4-M8	6-M10	6-M10
b3	6-M3	6-M4	6-M5	6-M6	6M-6	6M-8	6-M12
c1	9.6	11.6	12.6	14.7	19.7	23.3	27
c2	12	14	19	24	31	39	42
c4	18	20	22	24	26	30	35
c5	5.6	5.6	6.6	8.7	10	12.3	14
c6	3.5	4.5	5	5	6	7	8
d1	Ø37	Ø42	Ø52	Ø62	Ø80	Ø100	125
d3	Ø29	Ø38	Ø42	Ø49	Ø65	Ø92	105
d4	Ø80	Ø100	Ø125	Ø150	Ø190	Ø230	290
d5	Ø72	Ø92	Ø112	Ø137	Ø175	Ø215	270
d6	Ø63	Ø80	Ø100	Ø125	Ø165	Ø200	250
d7	Ø74	Ø60	Ø76	Ø94.5	Ø118	Ø134	210
s	0.2	0.2	0.2	0.3	0.3	0.4	0.6
h	400mm						
T	2	2.5	3	3,5	4	5	6
k	5	5-6	6-8	8	10-12	12-14	20
ağırlık(kg)	0.25	0.50	1.2	2.2	4,5	6	10

**DAF-M1 MONTAJ ÖLÇÜLERİ**  
DAF-M1 Assembly Measurement

DAF

SERİSİ / SERIES

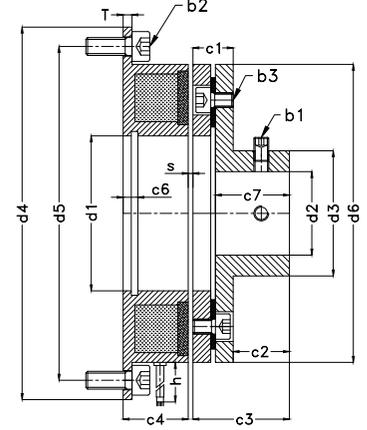
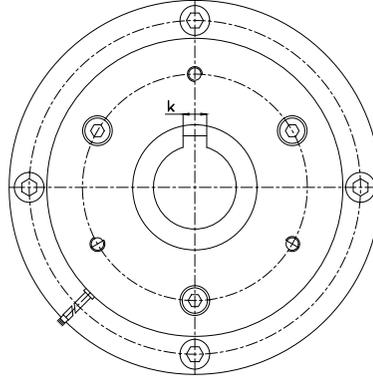
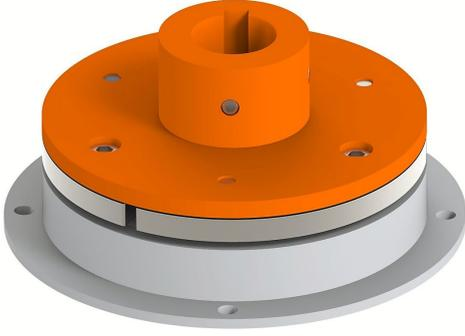

**Teknik Özellikler / Technical Specifications**

Tip/Type	DAF-01	DAF-02	DAF-03	DAF-04	DAF-05	DAF-06	DAF-07
Nm	8	16	32	65	120	240	480
b1	M4	M4	M5	M5	M6	M8	M10
b2	4-M4	4-M5	4-M6	4-M6	4-M8	6-M10	6-M10
b3	6-M3	6-M4	6-M5	6-M6	6-M6	6-M8	6-M12
c1	9.6	11.6	12.6	14.7	19.7	23.3	27
c2	12	14	19	24	31	39	42
c3	21.6	25.6	31.6	38.7	50.8	62.3	69
c4	18	20	22	24	26	30	35
c6	3.5	4.5	5	5	6	7	8
c7	16	20	25	30	40	50	55
d1	Ø37	Ø42	Ø52	Ø62	Ø80	Ø100	Ø125
d2(max.)	14/16	19/25	24/28	24/30	38/42	42/52	70
d3	Ø29	Ø38	Ø42	Ø49	Ø65	Ø92	Ø105
d4	Ø80	Ø100	Ø125	Ø150	Ø190	Ø230	Ø290
d5	Ø72	Ø92	Ø112	Ø137	Ø175	Ø215	Ø270
d6	Ø63	Ø80	Ø100	Ø125	Ø165	Ø200	Ø250
s	0.2	0.2	0.2	0.3	0.3	0.4	0.6
h	400mm						
T	2	2.5	3	3.5	4	5	6
k	5	5-6	6-8	8	10-12	12-14	20
ağırlık(kg)	0.25	0.50	1.2	2.2	4,5	6	10

DAF

SERİSİ / SERIES

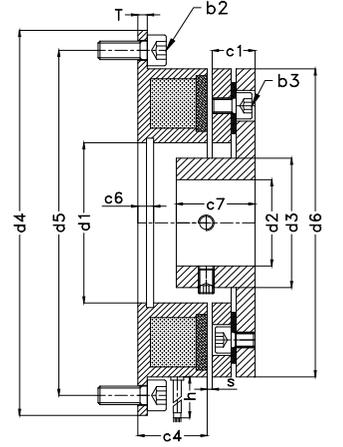
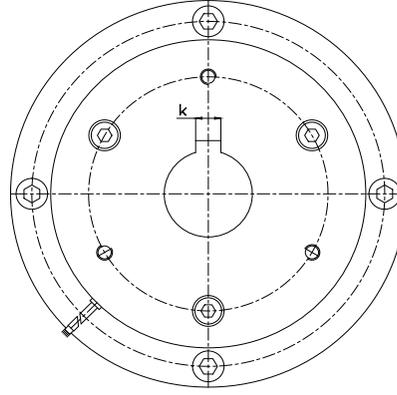
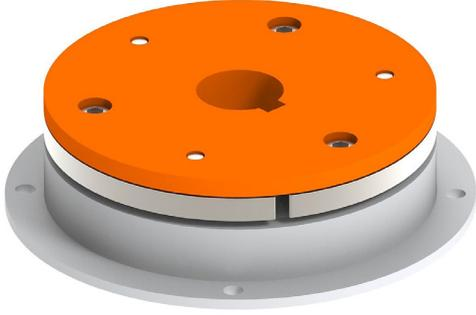
DAF-M2 MONTAJ ÖLÇÜLERİ  
DAF-M2 Assembly Measurement

## Teknik Özellikler / Technical Specifications

Tip/Type	DAF-01	DAF-02	DAF-03	DAF-04	DAF-05	DAF-06	DAF-07
Nm	8	16	32	65	120	240	480
b2	4-M4	4-M5	4-M6	4-M6	6-M8	6-M10	6-M10
b3	6-M3	6-M4	6-M5	6-M6	6-M6	6-M8	6-M12
c1	9.6	11.6	12.6	14.7	19.7	23.3	27
c4	18	20	22	24	26	30	35
c6	3.5	4.5	5	5	6	7	8
c7	16	20	25	30	40	50	55
d1	Ø37	Ø42	Ø52	Ø62	Ø80	Ø100	125
d2(max.)	14/16	19/25	24/28	24/30	38/42	42/52	70
d3	Ø29	Ø38	Ø42	Ø49	Ø65	Ø92	105
d4	Ø80	Ø100	Ø125	Ø150	Ø190	Ø230	290
d5	Ø72	Ø92	Ø112	Ø137	Ø175	Ø215	270
d6	Ø63	Ø80	Ø100	Ø125	Ø165	Ø200	250
s	0.2	0.2	0.2	0.3	0.3	0.4	0.6
h	400mm						
T	2	2.5	3	3.5	4	5	6
k	5	5-6	6-8	8	10-12	12-14	16-20
ağırlık(kg)	0.25	0.50	1.2	2.2	4,5	6	10

Teknik Özellikler / Technical Specifications

Tip/Type	Fren Momenti Braking Moment $M_K$	Fren Açma Zamanı Braking Time $t_2$	Frenleme Gecikme Zamanı Connection Delay $t_{11}$	Frenleme Zamanı Brake Switching Time $t_{1DC}$	Elektriksel Güç Power $W 20^\circ$
<b>Dc Anahtarlama(Hızlı)</b>					
	$M_K$	$t_2$	$t_{11}$	$t_{1DC}$	$W 20^\circ$
DAF01	8	12	10	40	15
DAF02	16	16	18	45	20
DAF03	32	30	22	65	28
DAF04	65	55	36	85	35
DAF05	120	90	40	110	51
DAF06	240	120	45	125	68
DAF07	480	145	51	135	85

**Elektrik Bağlantısı:**

Frenlerin çalışması için DC akım gereklidir. Bobin gerilimi, Tip etiketinin yanı sıra fren gövdesinde de gösterilir (En fazla %  $\pm 5$  tolerans). Frenleri doğrultucular ya da başka uygun bir DC güç kaynağıyla çalıştırmak mümkündür. Fren ekipmanına bağlı olarak bağlantılar değişkenlik gösterebilir. Lütfen bağlantıları tam olarak Fren Bağlantı Şemasına göre uygulayın. (Hızlı açma kapama uygulamalarında DC Anahtarlama, Yavaş açma kapama uygulamalarında AC Anahtarlama).

**Electrical Connection:**

DC circuit is required for brake operation. Coil voltage is shown on the nameplate as well as on the brake caliper. (Max. %  $\pm 5$  tolerance) It is possible to operate the brakes with rectifiers or other suitable DC power source. Depending on the brake equipment connections may vary. Please apply the connections exactly according to the Brake Connection Diagram. (For fast switching applications use DC switching, for slow switching applications use AC switching.)

**Frenlerin Açma Kapama Davranışları:**

Bir frenin çalışma davranışı, büyük ölçüde kullanılan açma kapama şekline dayanmaktadır. Ayrıca açma kapama süreleri, sıcaklıktan ve balata baskı flanşı ile Fren Bobin Gövdesi arasındaki hava boşluğundan etkilenir. (Bu özellikle balataların aşınma durumuna bağlıdır ve balata kalınlıkları periyodik olarak kontrol edilmelidir).

**Switching Characteristics of Brakes:**

A brakes operating characteristics highly depends on the switching mode used. Additionally, switching durations are affected by the temperature and the air gap between the pad flange and the brake coil body.(Especially, this depends on pad wearing condition so pad thicknesses must be checked periodically.)

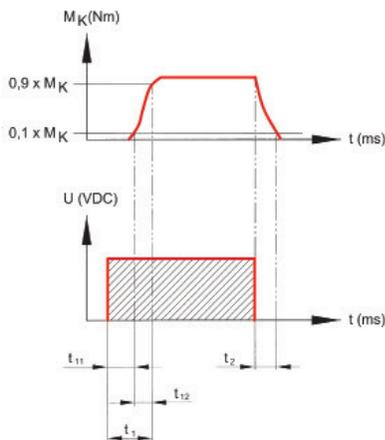

- $M_k$  :Frenleme Momenti / Braking Moment
- $t_1$  :Frenleme Zamanı /Braking Time
- $t_{11}$  :Bağlantı Geçikme Süresi /Connection Delay
- $t_2$  :Fren Açma Kapama Zamanı / Brake Switching Time
- $t_s$  :Bekleme Zamanı / Waiting Time

### Merkez / Factory

Altıkulaç Cd. No:109 İnebolu-Kastamonu/Türkiye

+90 (366) 811 41 17 - 811 58 58

+90 (366) 811 44 02

dereli@derelifren.com.tr

### İstanbul Şube / İstanbul Branch

Orhangazi Mah. 1725 Sk.  
Mimsan San. Sit. 38/A BLOK NO:75  
ESENYURT/İSTANBUL

+90(212) 672 16 56 - 672 16 57

+90 (212) 672 16 58

dereli@derelifren.com.tr

**Turkey**

444  
633  
76

[www.derelifren.com.tr](http://www.derelifren.com.tr)

