

# OPERATING INSTRUCTIONS

## P/R Series

Flange/Foot Mounted Planetary Gearboxes

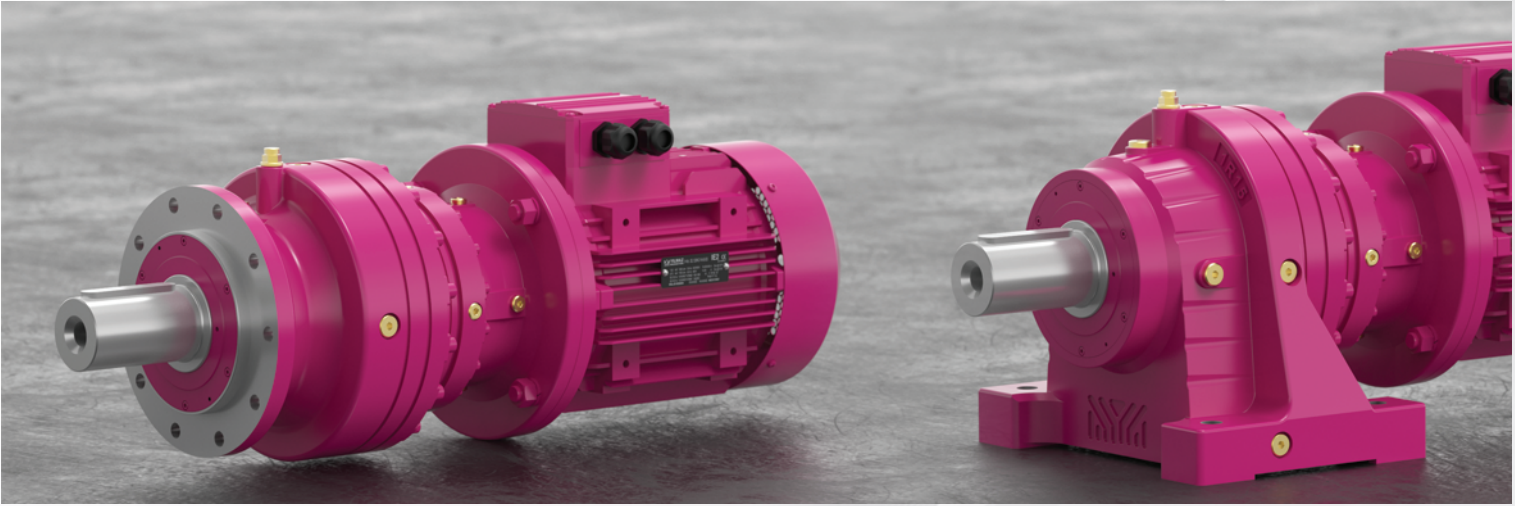



<b>Contents.....</b>	<b>03</b>
1 -How To Use This Manual .....	04
2 -Unit Designation .....	05
2.1- Detailed unit designation .....	05
2.2- Nameplate, unit designation.....	06
<b>3. Standard type Gearbox Part List.....</b>	<b>07</b>
3.1- P/R Output Group.....	07
3.2- Gear Group .....	
3.3 Input Side .....	16
<b>4- Safety .....</b>	<b>20</b>
4.1- Intended Use.....	21
4.2- Improper Use.....	21
4.3- Safety Instructions.....	22
4.3.1- General Safety Instructions.....	21
4.3.1.1- Working on the gear reducer.....	21
4.3.1.2- Operation .....	21
4.4- Tightening Torques.....	22
4.5- Case of Fire.....	22
<b>5 -Things to Check Before the Gear Unit or Geared Motor is Installed.....</b>	<b>23</b>
5.1- Transportation and Lifting.....	23
5.1.1 P...01L Types Lifting Positions .....	24
5.1.2 P...01K Types Lifting Positions .....	26
5.1.3 R...01K Types Lifting Positions.....	28
5.1.4 P Series Combined with E Series Lifting Positions .....	29
5.1.5 R Series Combined with E Series Lifting Positions .....	30
5.2- Storage.....	31
<b>6- Installing The Gear Unit.....</b>	<b>31</b>
6.1- Before you start.....	31
6.2- Check the shaft dimensions to fit .....	32
6.3- Check the ambient temperature .....	32
6.4- Check the voltage supply .....	32
6.5- Check the mounting position .....	35
6.6- Use of breather plug.....	35
6.7- Check the oil level .....	35
6.8- Check shaft ends and mounting faces .....	35
6.9- Cover abrasive ambient .....	35
6.10- Check accessibility to filling, breather and drain plugs.....	36



<b>7- Mechanical Installation .....</b>	<b>36</b>
7.1- Assembling customer shaft with shrink disc.....	37
7.2- Disassembling customer shaft with shrink disc.....	38
7.3- Assembling gear unit with torque arm.....	40
7.4- Fitting output shaft elements.....	42
7.5- Correct position of output shaft elements.....	42
7.6- Correct position of Splined Shaft output assembling .....	42
7.7- Fitting couplings .....	43
<b>8- Maintenance and Inspections .....</b>	<b>44</b>
<b>9- Lubrication .....</b>	<b>45</b>
9-1- Oil Types .....	45
9-2- Changing the oil .....	46
9-3- Mounting Positions .....	46
9-4- Oil Quantities. (lt) .....	51
9-5- Oil plugs .....	55
9-6- Oil Expansion Tank.....	59
<b>10- Hydraulic Motor .....</b>	<b>60</b>
<b>11- Troubleshooting Guide.....</b>	<b>62</b>
<b>12- Disposal .....</b>	<b>67</b>
11.1- Disposal of Oil .....	67
11.2- Disposal of Sealing.....	67
11.3- Disposal of Metal.....	67
<b>13- Appendix.....</b>	<b>68</b>
<b>Warranty Conditions.....</b>	<b>69</b>
<b>Warranty Declarations.....</b>	<b>70</b>



## 1 -How To Use This Manual

Take attention to the following safety and warning signs for proper understanding and quick reference.



Electric Hazard; Can cause severe or fatal injuries.



Mechanical Hazard; Can cause severe or fatal injuries.



Likely to be Hazardous; Can cause minor or fatal injuries



Damage Risk; Can damage the drive or environment



Important Information



### **EC Machinery Directive:**

Within terms of the EC machinery directive 2006/42/EC , the gear reducer is not considered an autonomous machine, but as a component to install in machines.

Operation is prohibited within the area of validity of the 2006/42/EC directive, until it has been determined that the machine, in which this product is installed, corresponds to the regulations within this directive.

The operating instructions contain important information to ensure;

- Trouble-free operation
- Fulfilment of any rights to claim under guarantee

The operating instruction must be kept close to the gearbox and must be available in case it is needed.

This operating instruction is written for P/R Series gear units and is applicable only for P/R Series. If any different type of gearbox is used please ask YILMAZ REDUKTOR for the operating instructions of that type.

This instruction can be used only for standard type geared units of YILMAZ REDUKTOR. For special application and modified gear units ask YILMAZ REDUKTOR for validity.

This manual does not cover 94/9/EC compatible gearboxes. For 94/9/EC contact YILMAZ REDUKTOR.





## 2- Unit Designation

### 2-1 Detailed Unit Designation

Detailed P Series gear units designation for ordering (This Designation is different from the short nameplate designation)

#### P N 11 0 2 L . 01 - Additional Information



#### Output Shaft Properties:

- 01 : Solid Output Shaft
- 0K : Splined Hollow Shaft DIN 5480
- 0L : Splined Hollow Shaft DIN 5482
- 0S : Shrink Disc
- 1K : Splined Solid Shaft DIN 5480
- 1L : Splined Solid Shaft DIN 5482

#### Optional for P24:

- 10 : Solid Output Shaft
- K0 : Splined Hollow Shaft DIN 5480
- L0 : Splined Hollow Shaft DIN 5482
- S0 : Shrink Disc
- K1 : Splined Solid Shaft DIN 5480
- L1 : Splined Solid Shaft DIN 5482

#### Shaft Condition:

- L: Input and Output Shafts on Same Axis
- K: Input and Output Shafts Perpendicular

#### Number of Stage:

- 1 : Single Stage
- 2 : Two Stage
- 3 : Three Stages
- 4 : Four Stages

#### Revision Number

#### Gearbox Sizes:

11,12, 15, 16, 19, 23, 24, 27, 29, 35

#### Version of Gearbox:

- V : With Electric or Hydraulic Motor
- N : Motor Connection Flange (IEC, C26, M46)
- T : Solid Input Shaft

#### Serie of Gearbox:

- P : Planetary Gearbox with Flange Mounted.
- R : Planetary Gearbox with Foot Mounted.

#### Additional Information: (For PN, PV, RN, RV)

##### - If the gearbox unit is PN, RN Type:

- A06 63 size IEC B5 motor connection flange
- A07 71 size IEC B5 motor connection flange
- A08 80 size IEC B5 motor connection flange
- A09 90 size IEC B5 motor connection flange
- A10 100 / 112 size IEC B5 motor connection flange
- A13 132 size IEC B5 motor connection flange
- A16 160 size IEC B5 motor connection flange
- A18 180 size IEC B5 motor connection flange
- A20 200 size IEC B5 motor connection flange
- A22 225 size IEC B5 motor connection flange
- A25 250 size IEC B5 motor connection flange
- C26 Flange code C, Shaft code 26 (HE Hydraulic Motor)
- M46 Flange code M, Shaft code 46 (HG Hydraulic Motor)

##### - If PN, RN type gearbox unit connected with hydraulic motor:

- HE330
  - Geometric displacement
  - Hydraulic motor type (HG or HE)

##### - If the gearbox unit is PV, RV type:

- 90S/4
  - Number of pole
  - Frame length
  - Motor size (63...-250...)

##### - If PN, RN type gearbox unit coupled with a worm gearbox:

- EV063-71/4b
  - Iron core length
  - Number of pole
  - Motor size (63...-132...)
  - Size of worm gearbox (63-125)
  - Worm gearbox type
    - EV: With motor
    - EN: With motor flange
    - ET: Without motor

#### Examples

PT1202K.01  
Without motor, solid output shaft, gearbox size 12, 2 stages, perpendicular input and output shaft with flange

PV1902L.01-160M/6  
Motor with 11 kW 900 rpm, solid output shaft, gearbox size 19, 2 stages, parallel input and output shaft with flange

RV1502L.00-90S/6  
Motor with 0,75 kW 900 rpm, hollow output shaft, gearbox size 15, 2 stages, parallel input and output shaft, with foot



PN1102L.01-EV063-71/4b  
Motor with 0,37 kW 1400 rpm, connected with worm gearbox size 63, solid output shaft, 2 stages, parallel input output shaft, planetary gearbox size 11 with flange



**i** 2.2- Nameplate, unit designation

Nameplate unit designation is a short abbreviation from the detailed designation

A sample name plate for P/R Series

		<b>YILMAZ REDÜKTÖR</b> www.yr.com.tr Made in Turkey			
<b>Type</b> : PV1902L.01.132M/4					
<b>Serial N.</b> :100109820					
⊕	<b>Power:</b> 7,5 kw	<b>Ratio</b> : 56,25			
	<b>Speed:</b> 16 rpm	<b>M.Position</b> : M1			
<b>Oil</b> : ISO VG 320 (Synthetic Oil)			<b>Oil Quantity:</b> 2.0 lt		

**Abbreviations:**

Serial N. : Serial Number

M.Position. : Mounting Position

**Type Designation;**

PV1902 L.01.132M/4

Type

Motor Type

**Output Shaft Properties:**

- 01...:Solid Output Shaft
- 0K...:Splined Hollow Shaft DIN 5480
- 0L...:Splined Hollow Shaft DIN 5482
- 0S...:Shrink Disc
- 1K...:Splined Solid Shaft DIN 5480
- 1L...:Splined Solid Shaft DIN 5482

Optional for P24:

- 10...:Solid Output Shaft
- K0...:Splined Hollow Shaft DIN 5480
- L0...:Splined Hollow Shaft DIN 5482
- S0...:Shrink Disc
- K1...:Splined Solid Shaft DIN 5480
- L1...:Splined Solid Shaft DIN 5482

**Shaft Arrangement**

L : Input and Output shafts are on same axis

K : Input and Output shafts are perpendicular each other.



### 3. Standard Type Gearbox Part List

#### 3.1- Output Group

##### 3.1-1 Version of Gearbox : RV / RN / RT

**Gearbox Size** :11 / 12 / 15 / 16 / 19 / 23 / 24 / 27 / 29 / 35

**Output Type** :01 / 1K / 1L

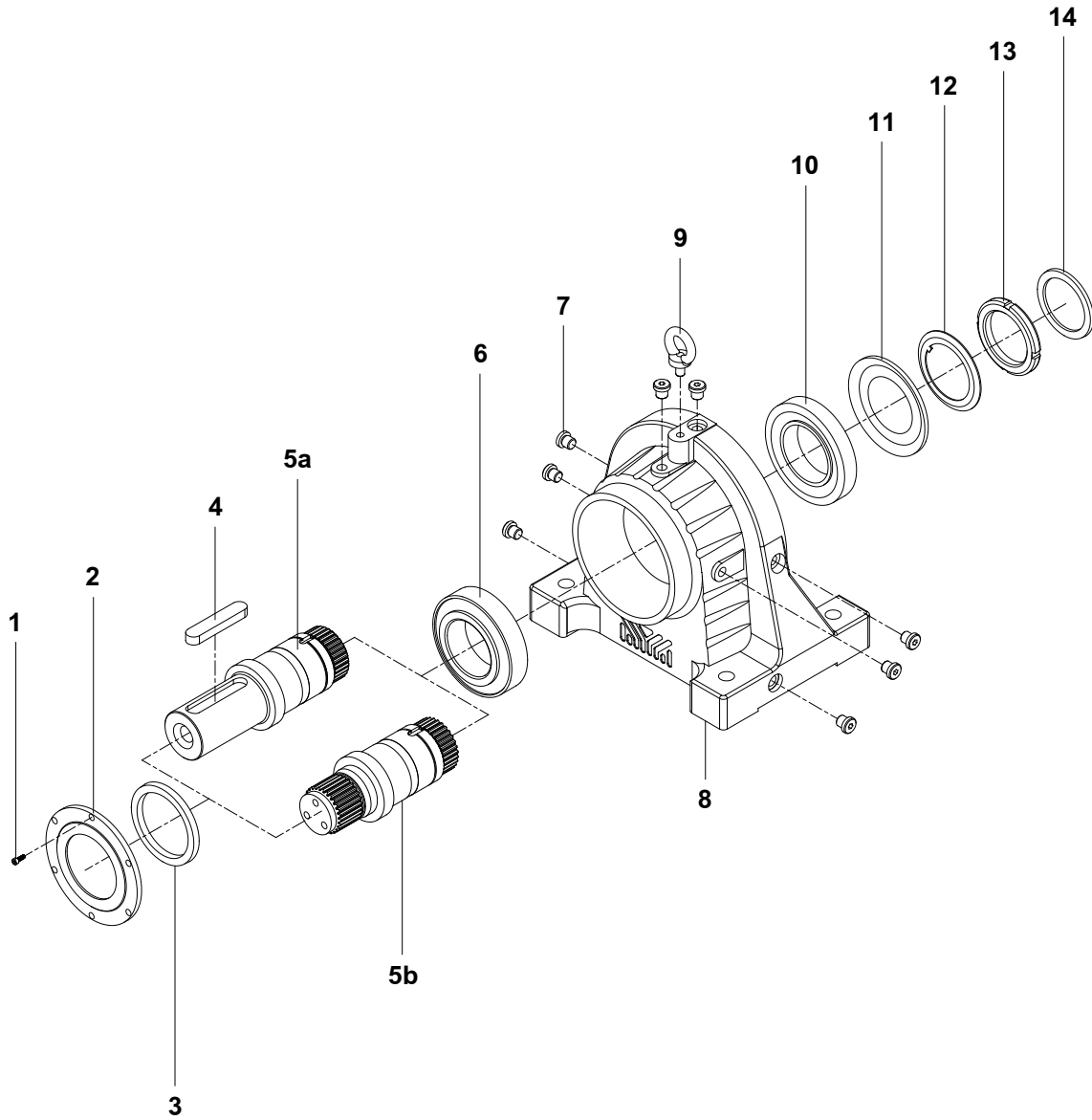

Parts may differ for special applications.

#### Standard Part List

1- Bolt	5b- Splined Output shaft	10- Bearing
2- Seal Cover	6- Bearing	11- Nilos Ring
3- Seal	7- Oil Plug	12- Tab washer
4- Key	8- Footed output	13- Locknuts
5a- Output Shaft	9- Lifting Bolts	14- Spacer



**3.1.2- Version of Gearbox : PV / PN / PT**  
**Gear Size :11 / 12 / 15 / 16 / 19 / 23 / 24**  
**Output Type :01 / 1K / 1L**

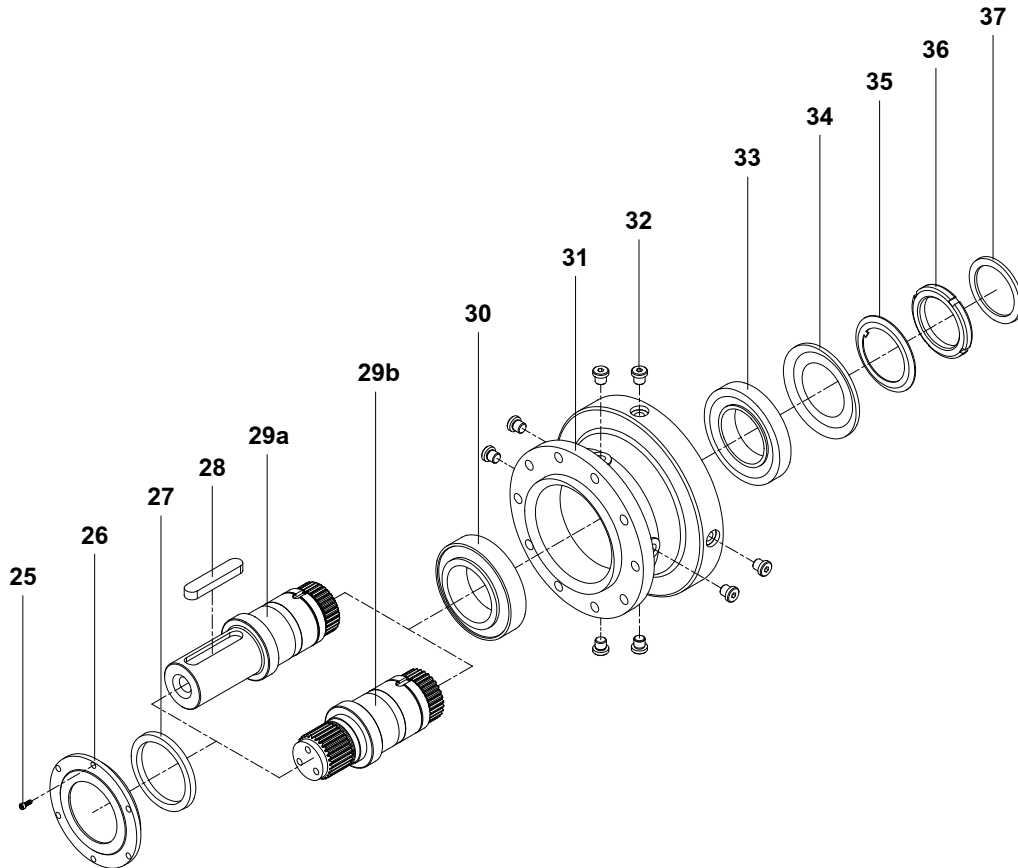

*Parts may differ for special applications.*

**Standard Part List**

25- Bolt	29b- Spline Output Shaft	34- Nilos Ring
26- Seal Cover	30- Bearing	35- Tab washer
27- Seal	31- Output Flange	36- Locknuts
28- Key	32- Oil Plug	37- Spacer
29a- Output Shaft	33- Bearing	



**3.1.3- Version of Gearbox : PV / PN / PT**  
**Gear Size :11 / 12 / 15 / 16 / 19 / 23 / 24**  
**Output Type :0S / 0K / 0L**

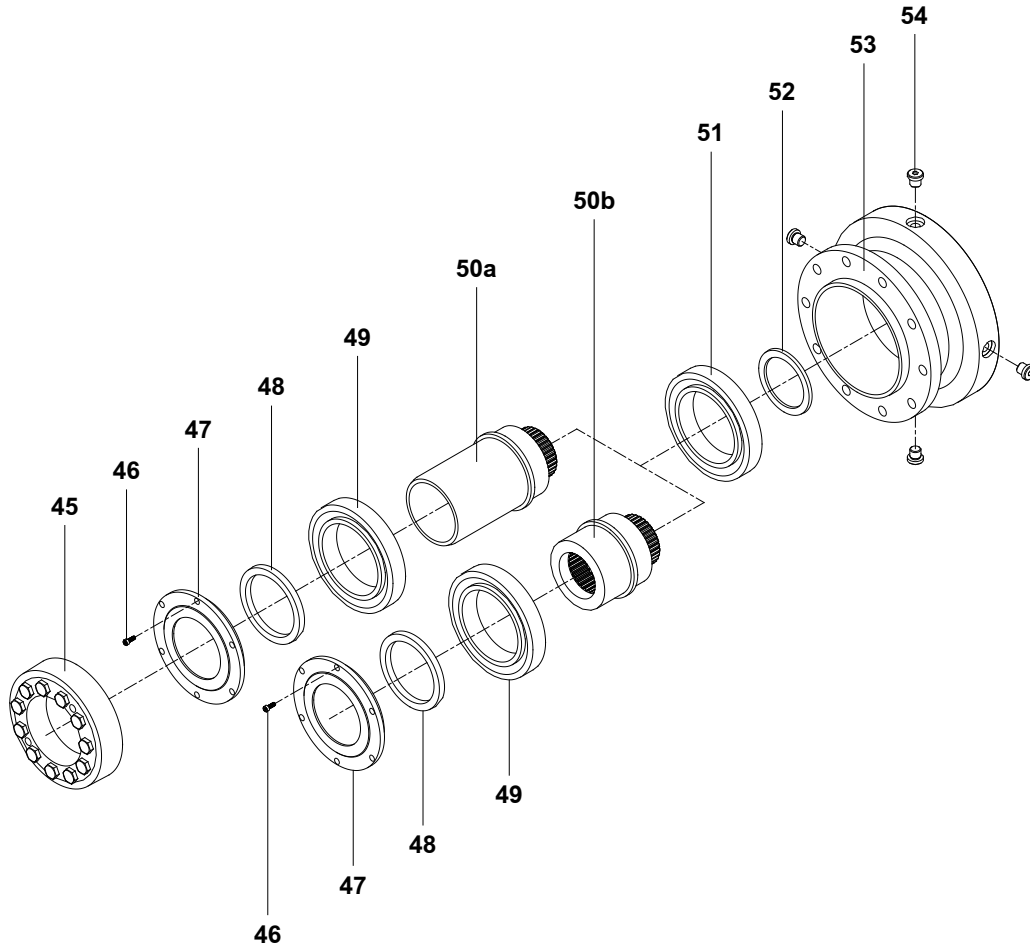

*Parts may differ for special applications.*

**Standard Part List**

45- Shrink Disc	50a- Hollow Shaft	54- Oil Plug
46- Bolt	50b- Spline Shaft	
47- Seal Cover	51- Bearing	
48- Seal	52- Spacer	
49- Bearing	53- Output Flange	



**3.1.4- Version of Gearbox : PV / PN / PT**  
**Gear Size : 27 / 29 / 35**  
**Output Type : 01 / 1K / 1L**

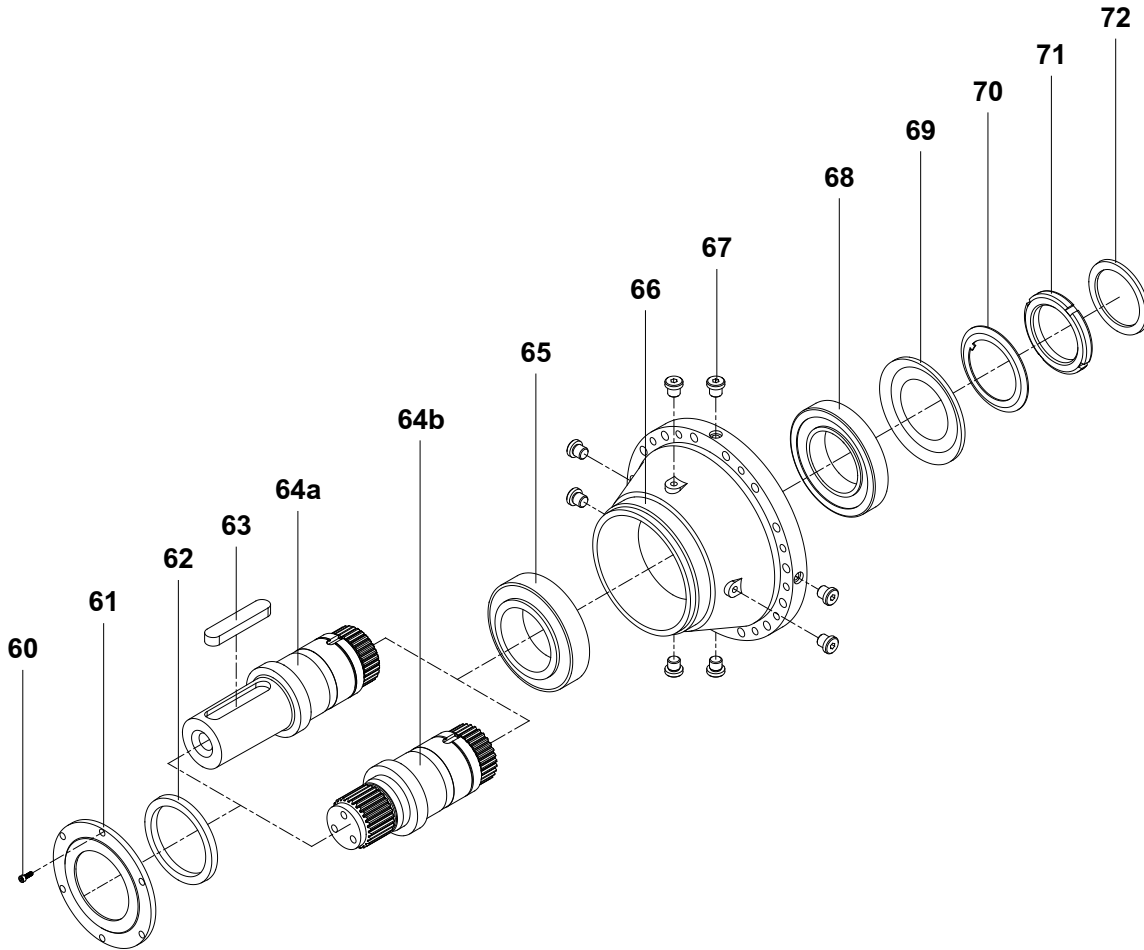

Parts may differ for special applications.

**Standard Part List**

60- Bolt	64b- Spline Output Shaft	69- Nilos Ring
61- Seal Cover	65- Bearing	70- Tab washer
62- Seal	66- Housing	71- Locknuts
63- Key	67- Oil Plug	72- Spacer
64a- Output shaft	68- Bearing	



3.1.5- Version of Gearbox : PV / PN / PT  
Gear Size : 27 / 29 / 35  
Output Type : S0

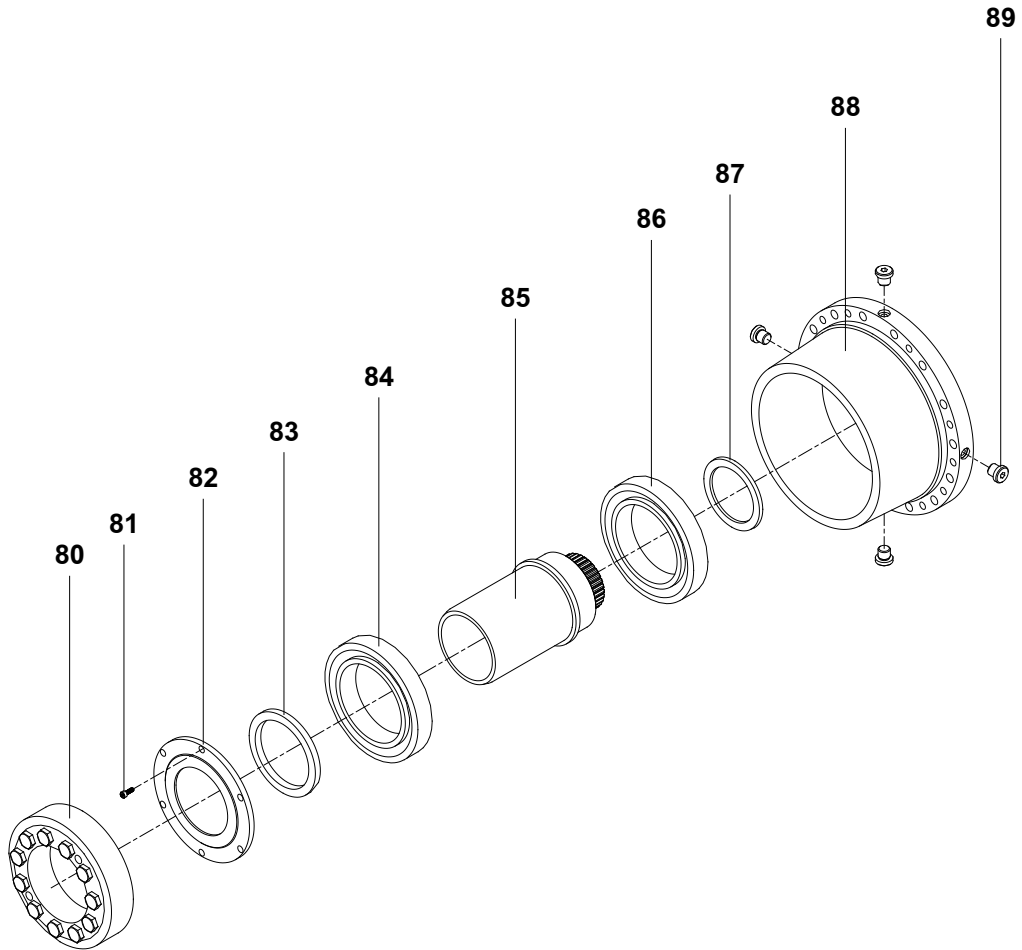

*Parts may differ for special applications.*



Standard Part List

80- Shrink Disc	85- Hollow Shaft
81- Bolt	86- Bearing
82- Seal Cover	87- Spacer
83- Seal	88- Output shaft
84- Bearing	89- Oil Plug

# Operating Instructions

## P/R Series

### Part Designations



**3.1.6- Version of Gearbox :** PV / PN / PT  
**Gear Size :** 27 / 29 / 35  
**Output Type :** 0K / 0L

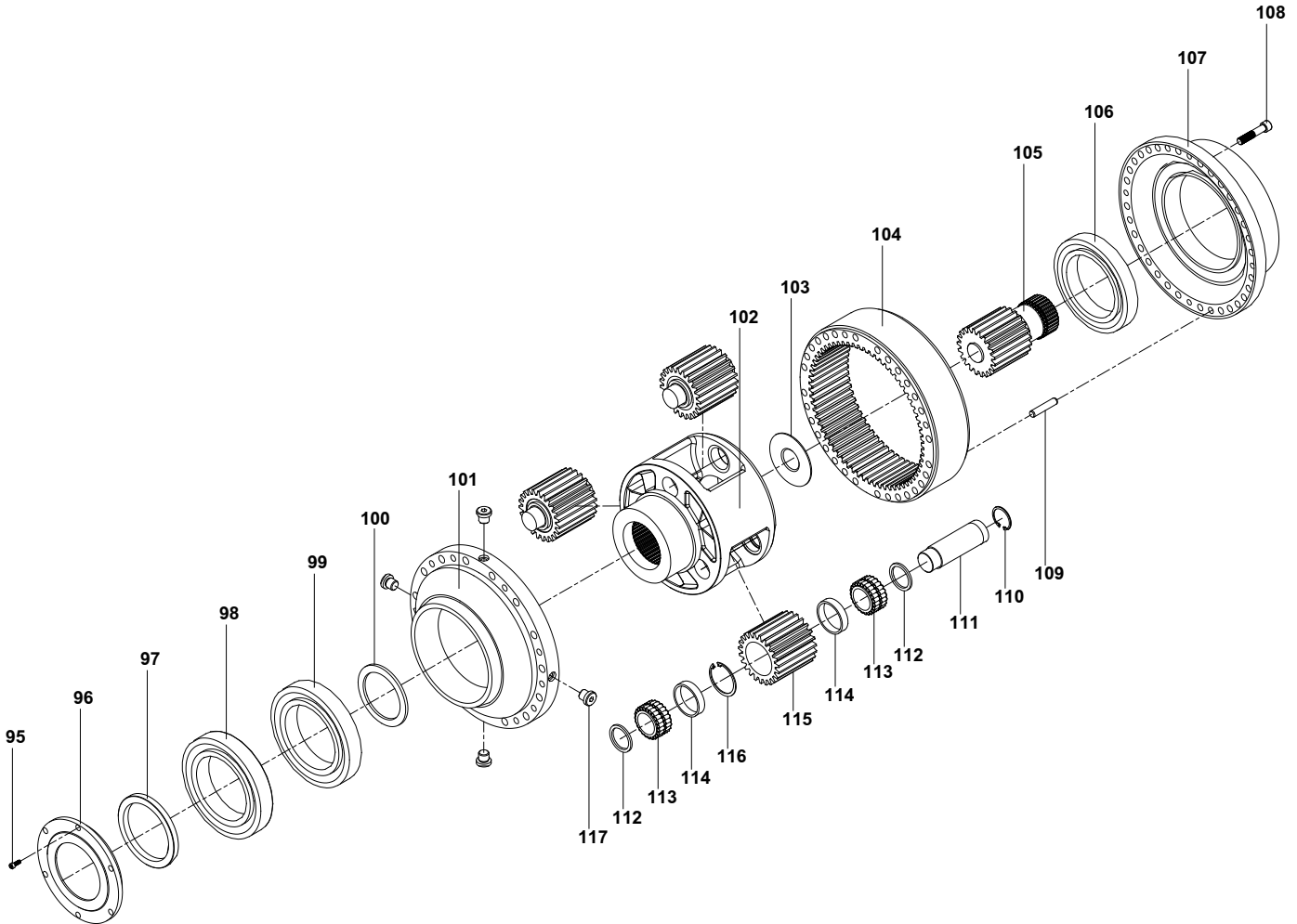

*Parts may differ for special applications.*

#### Standard Part List

95- Bolt	100- Spacer	105- Sun Gear	110- Circlip	115- Planetary Gear
96- Seal Cover	101- Output shaft	106- Bearing	111- Pin	116- Circlip
97- Seal	102- Carrier	107- Flange	112- Washer	117- Oil Plug
98- Bearing	103- Washer	108- Bolt	113- Bearing	
99- Bearing	104- Internal Gear	109- Pin	114- Spacer	



3.1.7-Version of Gearbox : PV / PN / PT

Gear Size :29 / 35  
Output Type :0S

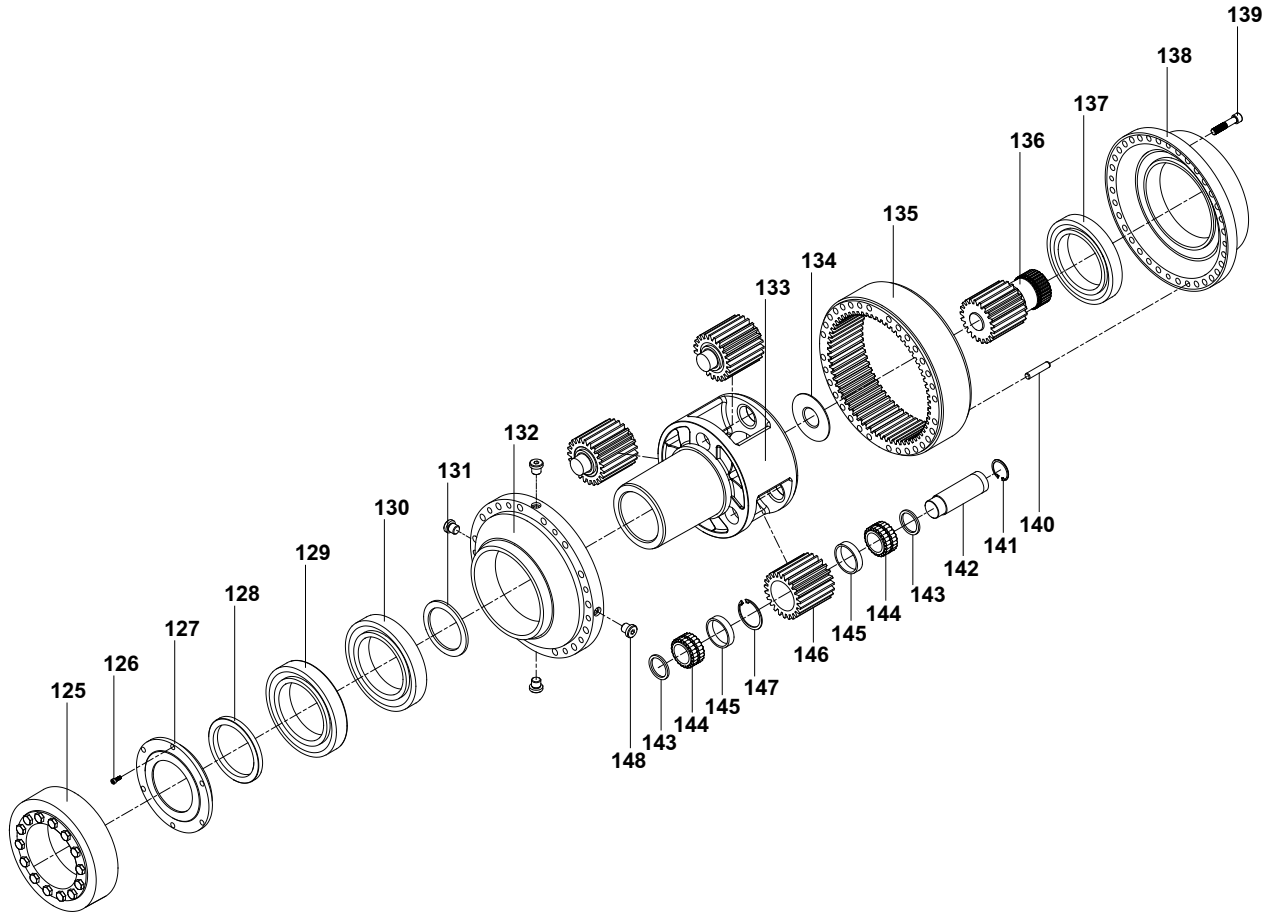

Parts may differ for special applications.

Standard Part List

125- Shrink Disc	130- Bearing	135- Internal Gear	140- Pin	145- Spacer
126- Bolt	131- Spacer	136- Sun Gear	141- Circlip	146- Planetary Gear
127- Seal Cover	132- Output Flange	137- Bearing	142- Pin	147- Circlip
128- Seal	133- Carrier	138- Flange	143- Spacer	148- Oil Plug
129- Bearing	134- Washer	139- Bolt	144- Bearing	



### 3.2- Gear Group

3.2.1 Version of Gearbox : PV / PN / PT / RV / RN / RT

Gear Size :11/ 15

Output Type : ALL

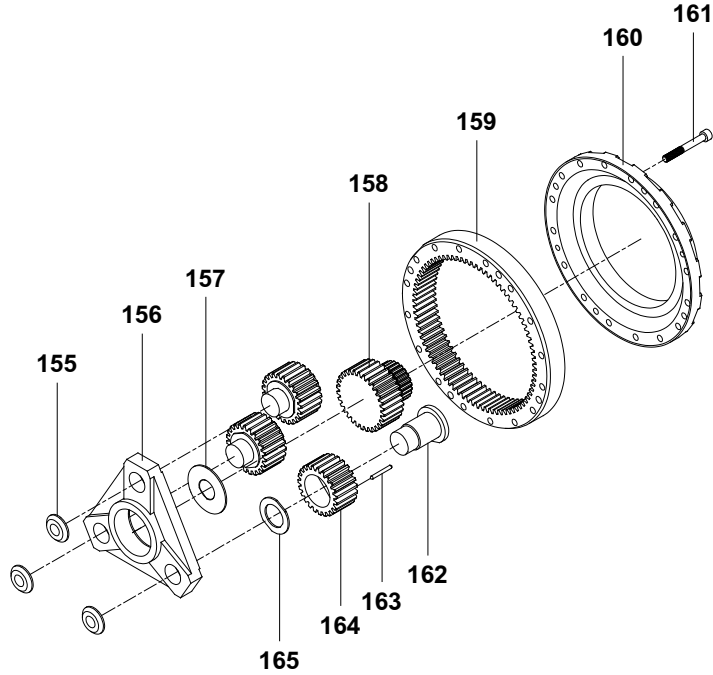

Parts may differ for special applications.

#### Standard Part List

155- Washer	160- Flange	165- Washer
156- Carrier	161- Bolt	
157- Washer	162- Pin	
158- Sun Gear	163- Needle Roller	
159- Internal Gear	164- Planetary Gear	



3.2.2 Version of Gearbox : PV / PN / PT / RV / RN / RT  
 Gear Size :12 / 16 / 19 / 23 / 24 / 27 / 29 / 35  
 Output Type :ALL

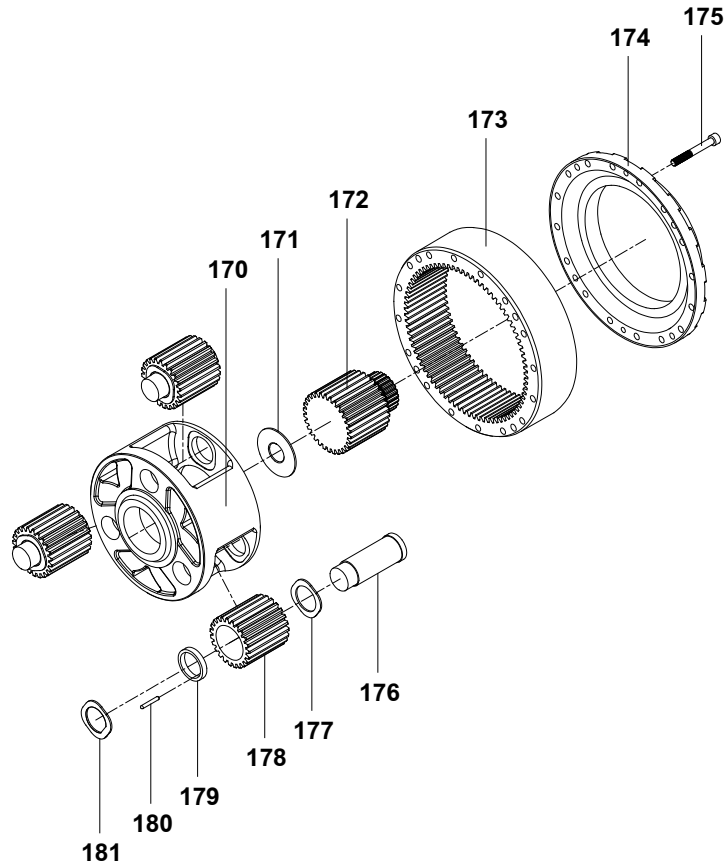

Parts may differ for special applications.

Standard Part List

170- Carrier	175- Bolt	180- Needle Roller
171- Spacer	176- Pin	181- Washer
172- Sun Gear	177- Spacer	
173- Internal Gear	178- Planetary Gear	
174- Flange	179- Spacer	



**3.2.3 Version of Gearbox :** PV / PN / PT / RV / RN / RT  
**Gear Size :** 11 / 12 / 15 / 16 / 19 / 23 / 24 / 29 / 35  
**Output Type :** ALL

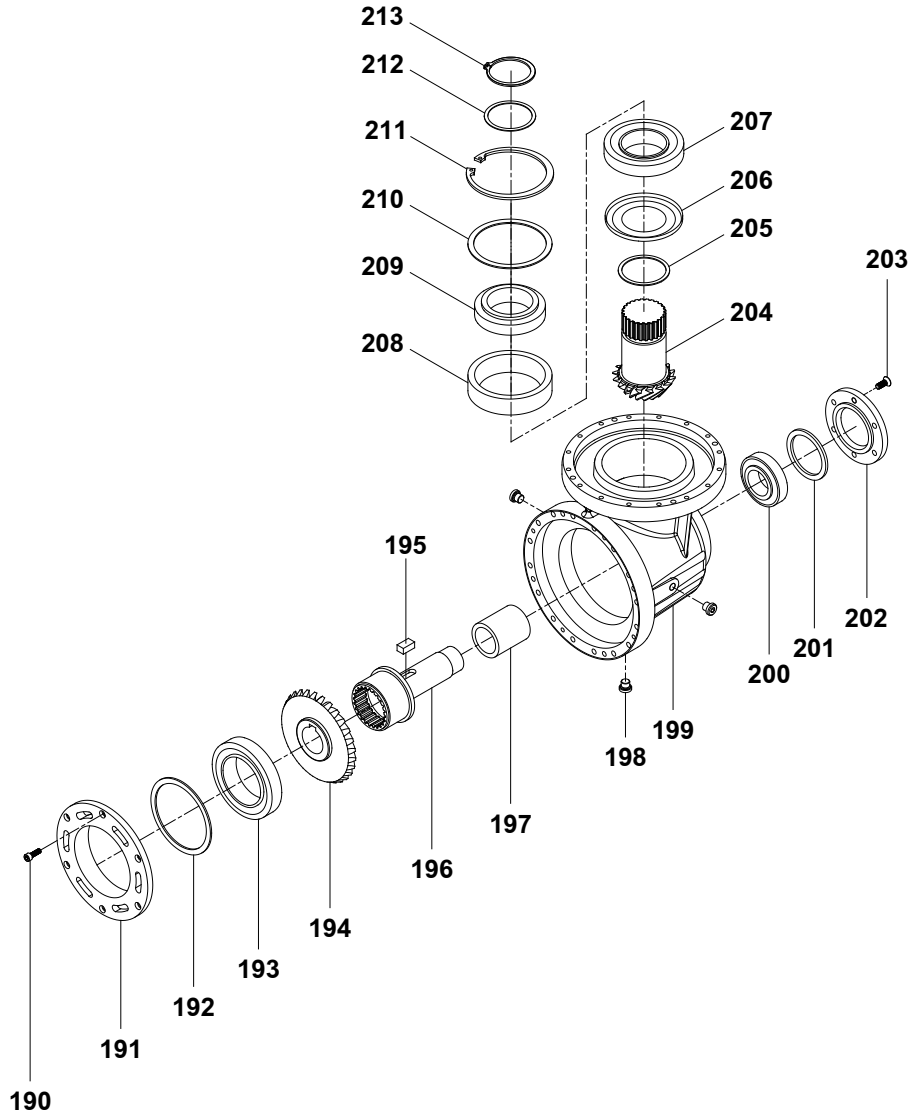

*Parts may differ for special applications.*

Standard Part List

190- Bolt	195- Key	200- Bearing	205- Spacer	210- Spacer
191- Seal Cover	196- Shaft	201- Spacer	206- Nilos Ring	211- Circlip
192- Seal	197- Spacer	202- Cover	207- Bearing	212- Washer
193- Bearing	198- Oil Plug	203- Bolt	208- Spacer	213- Circlip
194- Bevel Gear	199- Flange	204- Gear	209- Bearing	





### 3.3 Input Side

3.3.1 Version of Gearbox : PV / PN / RV / RN

Gear Size : 11 / 12 / 15 / 16 / 19 / 23 / 24 / 29 / 35

Input Type : IEC B5 Flange Type

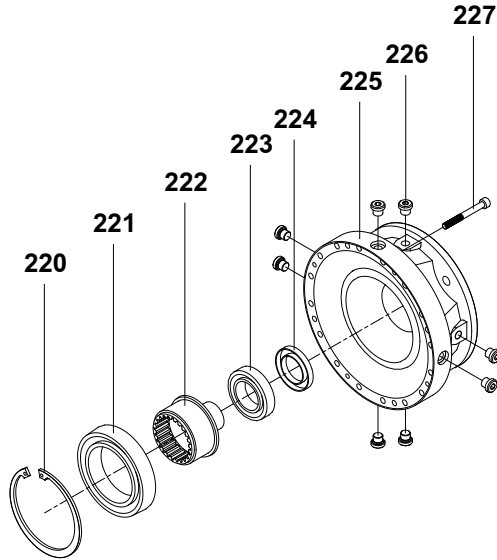

Parts may differ for special applications.

#### Standard Part List

220- Circlip	225- Input Flange
221- Bearing	226- Oil Plug
222- Input Shaft	227- Bolt
223- Bearing	
224- Seal	



3.3.2 Version of Gearbox : PV / PN / RV / RN  
Gear Size : 11/ 12 / 15 / 16 / 19 / 23 / 24 / 29 / 35  
Input Type : C26 / M46 input type for Hydraulic motor

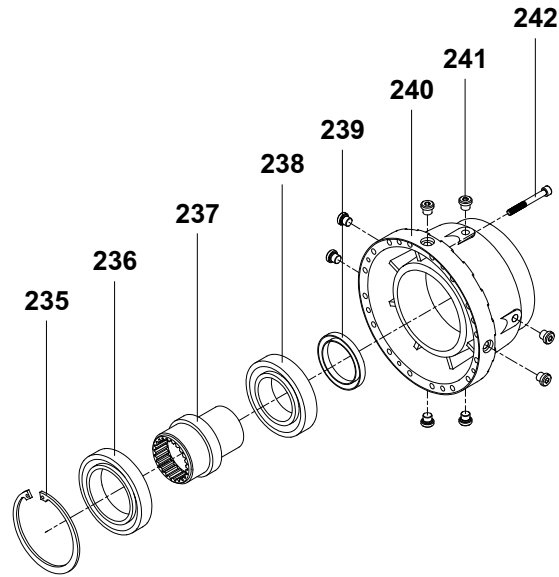

Parts may differ for special applications.

Standard Part List

235- Circlip	240- Input Flange
236- Bearing	241- Plug
237- Input Shaft	242- Bolt
238- Bearing	
239- Seal	

3.3.3 Version of Gearbox : PV / PN / RV / RN

Gear Size :11 / 12 / 15 / 16 / 19 / 23 / 24 / 29 / 35

Input Type :Solid input shaft

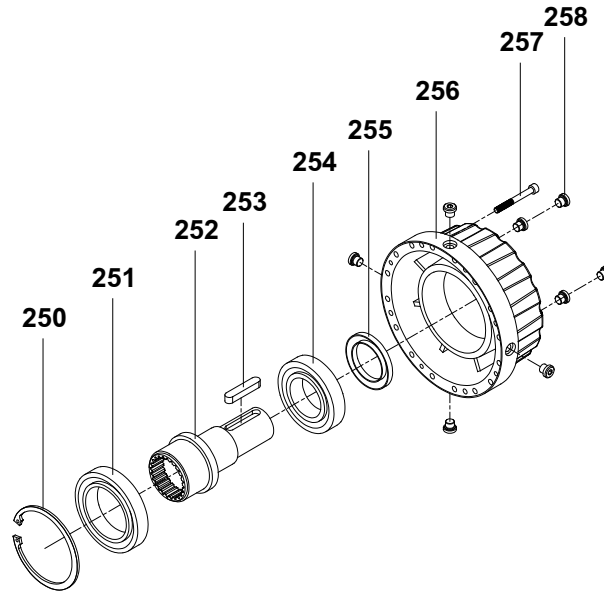

Parts may differ for special applications.

Standard Part List

250- Circlip	255- Seal
251- Bearing	256- Input Flange
252- Input Shaft	257- Bolt
253- Key	258- Oil Plug
254- Bearing	



## **4- Safety**

### **4.1- Intended Use**

The gear reducer is designed for use in industrial machines. Please refer to our catalogue or our web page for the maximum permitted torques and speeds. The most important maximum permitted values are indicated on the nameplate of the product. But the all data can be found on our product catalogues. Using the product out of the product catalogue/ nameplate's permitted ranges will cancel the warranty/manufacturer declaration and YILMAZ REDUKTOR will not take any responsibility.

The gear units are intended for industrial machines and may only be used in accordance with the information provided in this manual the product catalogue and the nameplate of the gearbox. They comply with the applicable standards and regulations and meet the requirements of the directive 2006/42/EC. The gearbox must be started up, maintained and operated according this manual. The gearbox must be incorporated with 2006/42/EC confirming parts/machines.



*A motor connected to the gear unit is only allowed to be operated in the frequency entries so that the data provided on nameplate/catalogue of the gear unit is not exceeded and is accordance with the nameplate/catalogue. The speed range will be provided on the name plate if YILMAZ REDUKTOR is informed that the gear unit will be used with frequency inverter. If not informed the nameplate will have a single fixed speed and only this speed is allowed.*

*The electric motor and frequency inverter must be in accordance with 2006/42/EC*



*If the gear units input is used with variable speed gear unit, this must be informed to YILMAZ REDUKTOR before ordering and on the nameplate the allowed maximum and minimum speeds (speed range) will be provided. If not mentioned by ordering the gear units speed will be a fixed single input speed and only this speed is allowed.*



*If the gear unit will be driven by belt / coupling / chain drive etc. the gear unit is only allowed to be used according the nameplate/catalogue entries. Different speed, higher motor power, higher radial/axial loads etc. than nameplate/catalogue is not allowed.*



*The ambient temperature must be between +5 , +40 celsius and no abrasive media must attack the paint and seals. If different working conditions this must be informed to YILMAZ before ordering.*



*The gearbox maintenance (oil change / check ) must be done according this manual*

### **4.2- Improper Use**

Every usage which exceeds the limits stated above, the nameplate and catalogue of the product (especially highest torques and speeds) is not compliant with the regulations, and thus prohibited.

The operation of the gear reducer is prohibited if;

- It was not mounted/installed according to regulations and this manual
- The gear reducer is very soiled
- It is operated without lubricant
- It is operated out of the permitted values provided on catalogues and/or nameplate.



### 4.3- Safety Instructions

#### 4.3.1- General Safety Instructions

##### 4.3.1.1- Working on the gear reducer



- Inappropriately executed work can lead to injury or damage.

Make sure that the gear reducer is only installed, maintained and dismantled by trained technicians.



- Foreign bodies spinning through the air can cause grave injury.

Before putting the gear reducer into operation, check that there are no foreign bodies or tools near the gear reducer



##### 4.3.1.2- Operation

- Touching hot surfaces can lead to burns.

Do not touch the gear reducer if their operation temperatures are too high, or use suitable safety equipment like gloves.



-Rotating machinery can lead to injuries. There is danger of being trapped or pulled in!

Keep a sufficient distance and make safeguarding to rotating machinery. See relevant norms EN349+A1, EN13857.



##### 4.3.1.3- Maintenance

-An unintentional start of the machine during maintenance work can lead to serious accidents.

Make sure no one can start the machine while you are working on it.



- Even a brief running of the machine during maintenance work can lead to accidents if the safety devices are not operating.

Make sure that all safety devices are mounted and active.



##### 4.3.1.4- Lubricant

- Extended, intensive contact with oils can lead to skin irritations.

Avoid extended contact with oil, and clean oil off skin thoroughly.



- Hot oil can cause scalding.

When changing oil, protect yourself against contacting hot oil.



##### 4.3.1.5- Ambient Conditions

- Standard gearboxes are allowed to work in ambient temperatures between +5 to +40 celsius unless differently specified on the nameplate.

Using the gear unit out of this range can cause damage to the gear unit or environment. Over +40 celsius ambient conditions the gear unit surface temp could be so high causing burns when touched.



-If the gear unit will be used in outdoor applications the gear unit must be prevented from rain snow and dust. Entering substances inside the gear unit from seals can damage the gear unit. Observe the safety instructions for outdoor use EN12100:2010.

#### 4.4- Tightening Torques

All screwed connections for which a tightening torque is specified, must on principle be tightened with a calibrated torque wrench and checked. Use the following torques for the threaded bores over the gear unit housing. For connecting elements refer to the mechanical installation part.

Bolt Size	Class	Tightening Torque [Nm]
M5	8.8	5.4
M6	8.8	9
M8	8.8	23
M10	8.8	43
M12	8.8	77
M16	8.8	190
M20	8.8	370
M24	8.8	640

#### 4.5- Case of Fire

The gear reducer itself is not combustible. However, it usually contains a synthetic or mineral gear oil.

Please observe the following if the gear reducer is situated in a burning environment



##### 4.5.1- Suitable extinguishing agents, Protective equipment

Always keep suitable extinguishing, protective equipment like carbon dioxide, powder, foam, fog easily accessible around the gear unit.

-High temperature produce irritating steam.

Use a protective breathing apparatuses.



##### 4.5.2- Unsuitable extinguishing agents

Do not spray with water!





## 5 -Things to Check Before the Gear Unit or Geared Motor is Installed

*If gear motors are used, please also refer to the manual of the motor manufacturer.*



Before you install the gearbox you have to be sure that the gearbox is arrived with the all necessary equipment and without damage. Think to take into consideration before you start to install the unit;

- You have received the correct operation manual of the your product.
- The gearbox and all its parts are transported without damage.
- The gearbox is stored correctly according the instructions in this manual
- You have the latest product catalogue or you have access to our web page.

### 5.1- Transportation

When the goods arrive, first check for any damage. If some damage observed, immediately contact the transport company and inform about the damage. Contact YILMAZ REDUKTOR for the damage and do not start to install the unit until it is agreed that the damage has no effect of operation.

*Please use the rope for lifting and carrying by wrapping around the gearbox or use the eyebolt indicated position as shown on next pages. If you can not find lifting adequate pictures for your product please contact YILMAZ REDUKTOR. The eyebolts should be capable to carry the weight of gearboxes. Do not hang additional loads on the gearbox by lifting. Use suitable hoisting equipment which is capable to hold the gear units weight. Refer to the catalogue for various types weights.*



*Do not stay beneath / under the lifting / hoisting equipment which may cause serious injuries by falling down objects, accidental movements, unexpected accidents.*



*Falling or hard placement can damage the gear unit.*

*Only use hoisting and securing equipment which is permitted for the size / weight of your gear unit. Ensure that the load is slowly and carefully handled and placed.*



*Lifting and carrying types are indicated on following pages.*



**5.1.1 P..01L Types Lifting Positions**

Type	Single Stage	MultiStage
<p><b>PV..01L</b>                      (For P11 To P24)</p>		
<p><b>PV..01L*</b>                      (For P24 To P35)</p>		
<p><b>PN..01L</b>                      (For P11 To P24)</p>		

**Operating Instructions**  
**P/R Series**  
**Lifting**

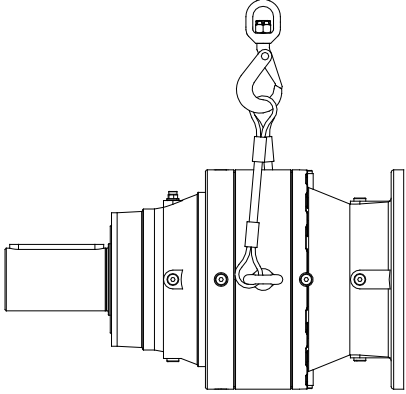
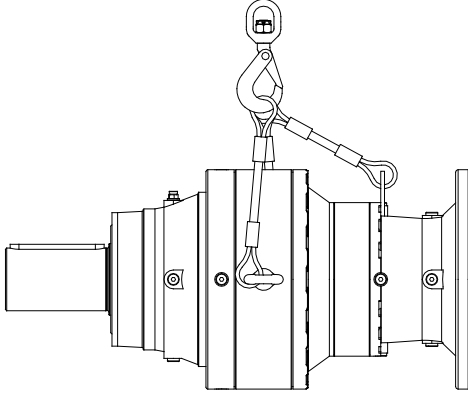
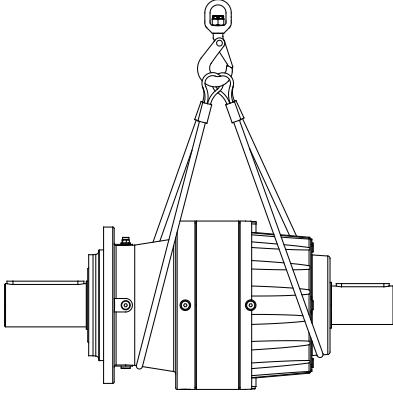
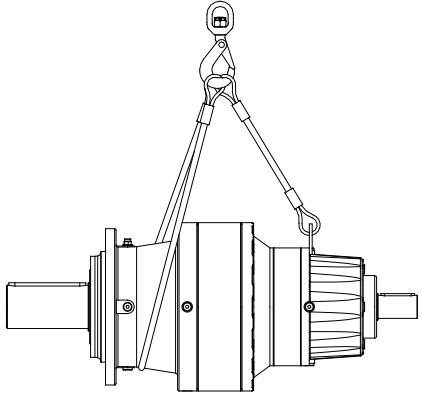
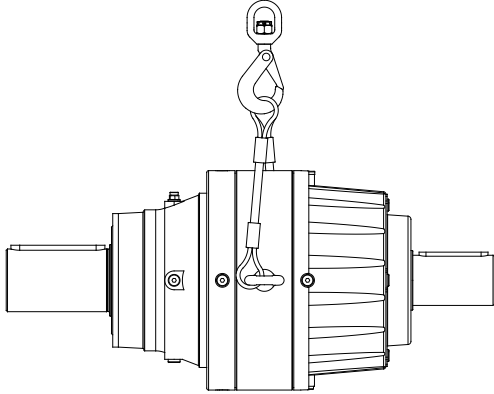
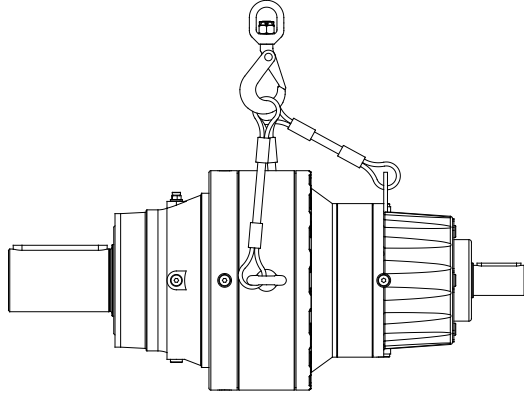

**5.1.1 P..01L Types Lifting Positions**

Type	Single Stage	MultiStage
<p><b>PN..01L*</b> (For P11 To P24)</p>		
<p><b>PT..01L</b> (For P11 To P24)</p>		
<p><b>PT..01L*</b> (For P24 To P35)</p>		

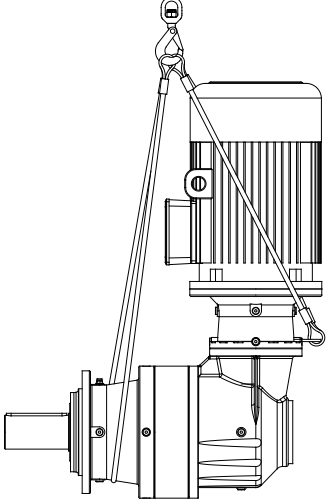
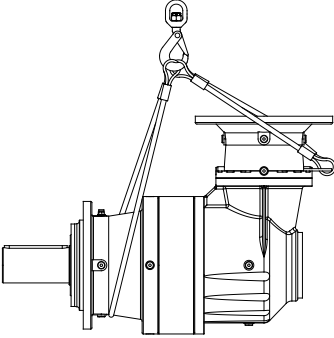
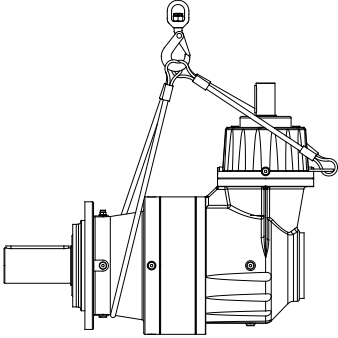

#### 5.1.2 P..01K Types Lifting Positions

Type	Single Stage	MultiStage
<p><b>PV..01K</b> (For P11 To P24)</p>	<p><b>NOT APPLICABLE</b></p>	
<p><b>PN..01K*</b> (For P24 To P35)</p>	<p><b>NOT APPLICABLE</b></p>	
<p><b>PT..01K</b> (For P11 To P24)</p>	<p><b>NOT APPLICABLE</b></p>	



**5.1.2 R...01L Types Lifting Positions**

Type	Single Stage	MultiStage
RV.01L		
RN.01L		
RT.01L		

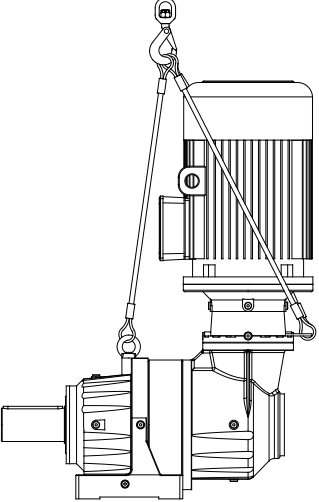
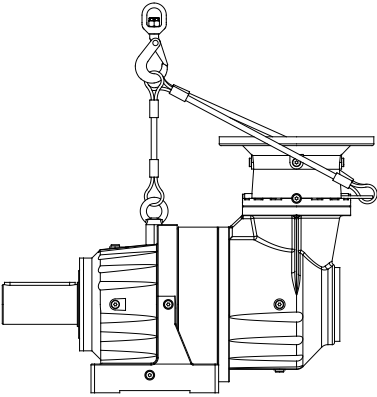
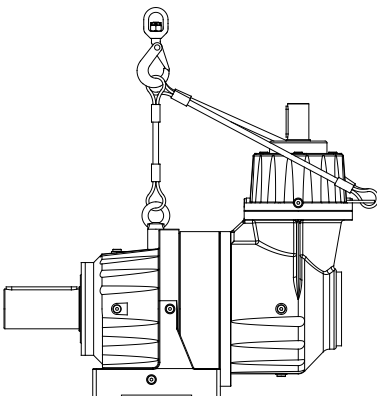

**5.1.3 R...01K Types Lifting Positions**

Type	Single Stage	MultiStage
RV.01K	<b>NOT APPLICABLE</b>	
RN..01K	<b>NOT APPLICABLE</b>	
RT..01K*	<b>NOT APPLICABLE</b>	





**5.1.4 P Series Combined with E Series Lifting Positions**

Type	For P11 To P24	For P27 to P35
<p><b>PN...L.01+EV125</b></p>		
<p><b>PN...L.01+EN125</b></p>		
<p><b>PN...L.01+ET125</b></p>		

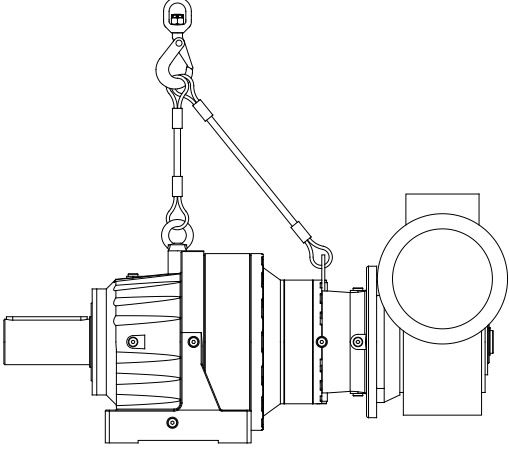
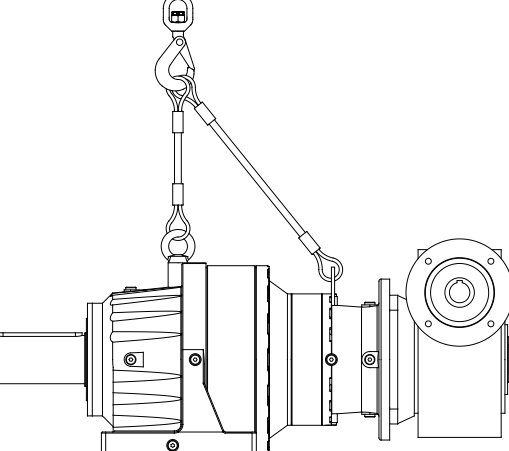
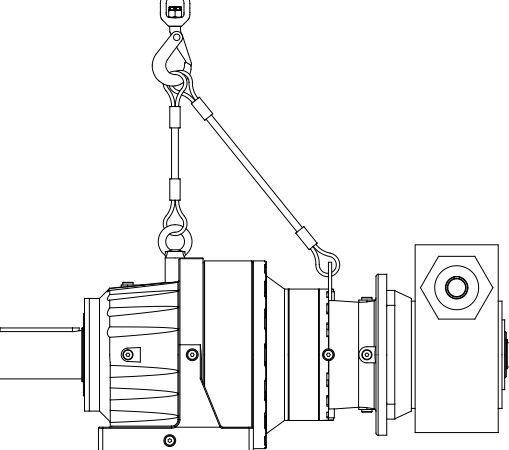

**5.1.5 R Series Combined with E Series Lifting Positions**

Type	For P11 To P24	For P27 to P35
<p><b>RN...L.01+EV125</b></p>		<p><b>NOT APPLICABLE</b></p>
<p><b>RN...L.01+EN125</b></p>		<p><b>NOT APPLICABLE</b></p>
<p><b>RN...L.01+ET125</b></p>		<p><b>NOT APPLICABLE</b></p>



## **5.2- Storage**

If the geared unit or geared motor will be stored up to 3 years refer to the following instructions;

### **With Packing;**

-Use corrosion protection oil for the output shaft and connection surfaces like flange surface or foot assembling surface. Seal the unit in a plastic wrap and pack it in container. A moisture indicator should be placed around the container to observe the moisture. Relative atmospheric humidity should not exceed 50%. The container should be kept under roof which protects from snow and rain. Under this condition the gear unit can be stored up to 3 year with regular check. The ambient temperature should be between -5 to 60 Celsius degrees

### **Without Packing;**

-Use protection oil for the output shaft and connection surfaces like flange surface or foot assembling surface. If no packing is used and the gearbox is stored without packing, the ambient temperature should be between 5 to 60 Celsius degrees. The gearbox must be kept under enclosed roof with constant temperature and constant humidity not exceeding 50%. The storage should be free of dust and dirt and ventilated with filter. If the gearbox is stored without packing it is recommended not to store more than 2 years and regular check during this time is recommended.

If stored in open protect against insect damage.

## **6- Installing The Gear Unit**

### **6.1- Before you start;**

- Observe the gear unit for damages of storage or transportation. If any damage please contact YILMAZ REDUKTOR.
- Be sure that you have all the equipment necessary for installing like; Spanners, torque wrench, shims and distance rings, fixing devices for input and output elements, lubricant, bolt adhesive etc.

*- This manual is not for 94/9/EC (ATEX) conforming gear units. For 94/9/EC conforming gear units refer to the ATEX range manual. ATEX conforming gear units have name plates indicating the zone and the temperature class and are different from standard type geared units. Therefore Standard units can not be installed on Potentially explosive atmospheres.*





## 6.2- Check the shaft dimensions to fit

Type	Hollow Shaft Diameter with Shrink Disc	Tolerance (H7)	Customer Shaft Diameter with Shrink Disc	Tolerance (h6)	Solid Output Shaft Diameter	Output Shaft Tolerance
P11..	42	+0.03 0	42	0 -0.02	50	+0.02 0
P12..	52	+0.03 0	52	0 -0.02	50	+0.02 0
P15..	75	+0.03 0	75	0 -0.02	60	+0.02 0
P16..	75	+0.03 0	75	0 -0.02	60	+0.02 0
P19..	90	+0.04 0	90	0 -0.02	80	+0.02 0
P23..	100	+0.04 0	100	0 -0.02	90	+0.04 0.01
P24..	100	+0.04 0	100	0 -0.03	90	+0.04 +0.01
P27..	130	+0.04 0	130	0 -0.03	110	+0.04 +0.01
P29..	135	+0.04 0	135	0 -0.03	120	+0.04 +0.01
P35..	140	+0.04 0	140	0 -0.03	140	+0.04 +0.02

## 6.3- Check the ambient temperature;

The ambient temperature must be between +5 celsius to +40 celsius for standart type gear units. If different contact YILMAZ REDUKTOR for special solutions.



## 6.4- Check the voltage supply;

The standard geared motors are supplied with 230/400 V 50/60 Hz. up to 3kW including 3kW and 400/690 V 50/60 Hz. over 3 kW and is indicated on the motors name plate unless it is differently ordered. In case of only gear unit is supplied from YILMAZ please observe the name plate of the electric motor and the instructions of the supplier. Check the basic electric connection diagrams below. Use experienced electric technician.

Using wrong connection or voltage can damage the electric motor or environment.

# Operating Instructions

## P/R Series

### Checking



The following wiring diagram is for standard 230/400 V 50Hz AC electric motors. For different voltages please contact YILMAZ REDUKTOR. For gear units supplied without motor, refer to the motor manufacturers user Manuel.



The electric connection must be done by experienced electric technician.  
The gearbox, the motor and the brake must be grounded to prevent potential differences of earth and gearbox/motor.

Pole Number	Nominal Powers at 400V, 50Hz	
	230V ( $\Delta$ ) / 400 V ( Y )	400V ( $\Delta$ )
2 or 4	$\cong 3$ kW	$\geq 4$ kW
6	$\cong 2,2$ kW	$\geq 3$ kW
8	$\cong 1,5$ kW	$\geq 2,2$ kW
Starting Principle	Direct	Direct or Y/ $\Delta$

**Basic motor connection wiring diagram**

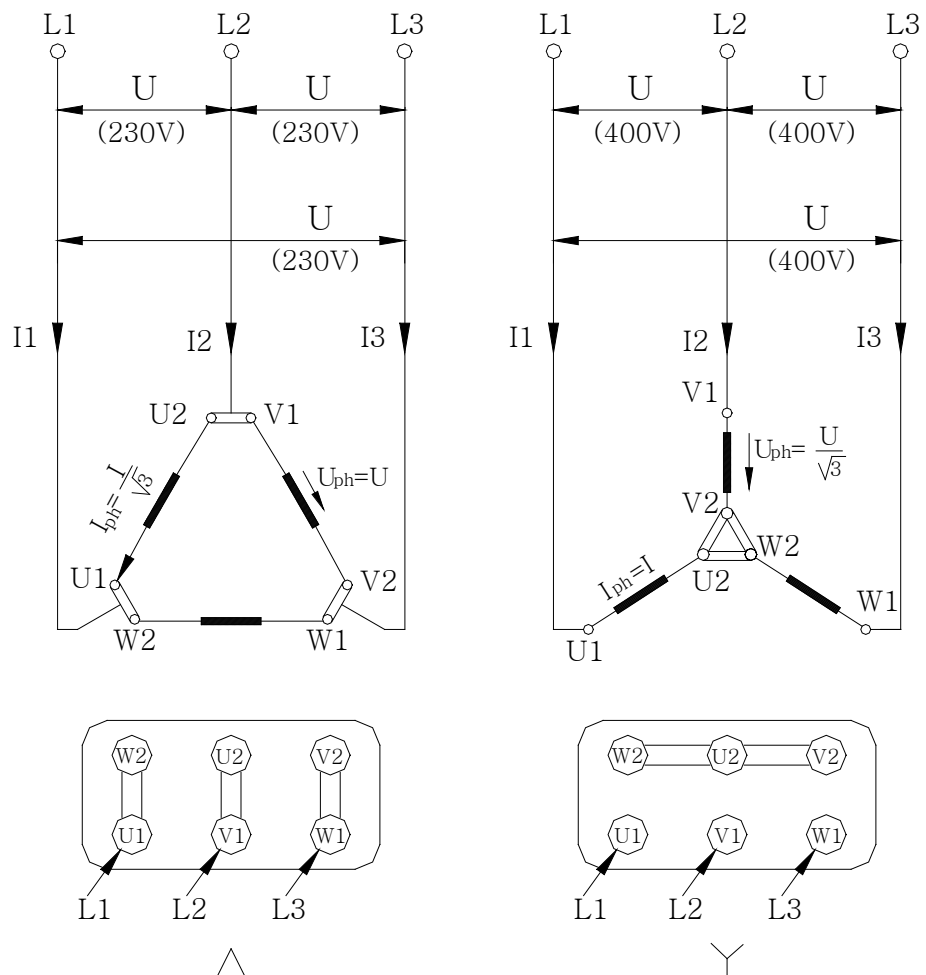



## Standard type brakes basic wiring diagram



The electric connection must be done by experienced electric technician.  
The gearbox and the motor must be grounded to prevent potential differences of earth and gearbox/motor.

Delayed Running Brake ( 220 V )

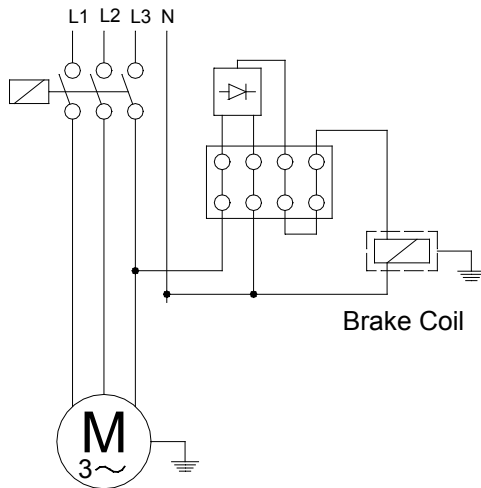

Sudden Brake ( 220 V )

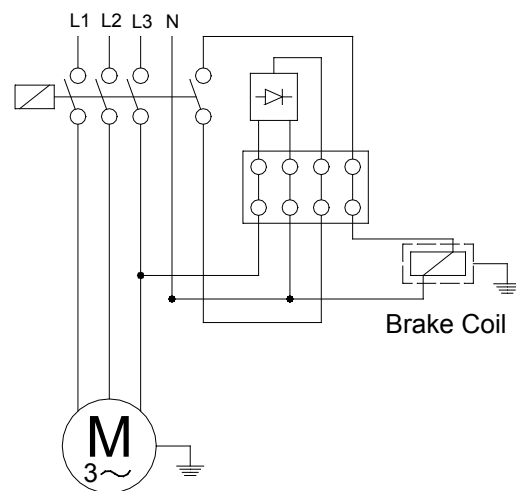

Delayed Running Brake 4 ( 24 V )

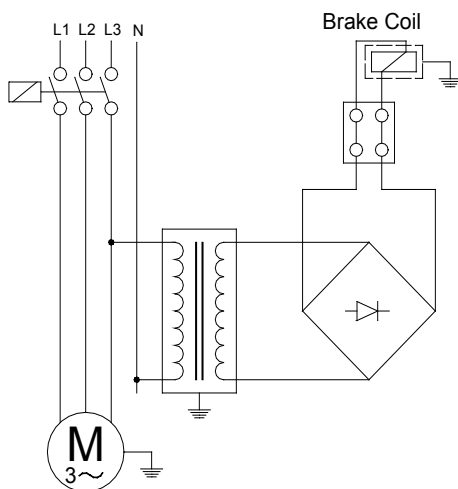

Sudden Brake ( 24 V )

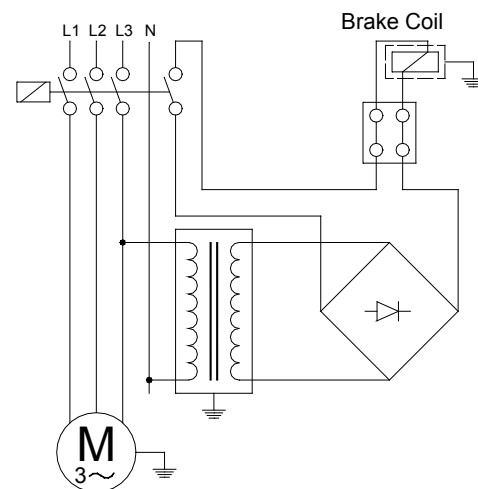



**6.5- Check the mounting position;**

The mounting position must be in accordance with the mounting position mentioned on the name plate. If different please contact YILMAZ REDUKTOR for possibilities of using in a different mounting position. Refer to the mounting positions and oil quantities on this manual and adjust the oil level accordingly with the recommended oil types given on this manual.



Do not mix synthetic oils with mineral oils which can cause serious damage on the gear unit.

**6.6- Use of breather plug;**

Breather plugs are not needed for P Series under normal ambient and working conditions (Up to 30 degree Celsius ambient temperature and up to 8 hours per day) . If heavy ambient conditions and long time working hours then breather plug are recommended by YILMAZ REDUKTOR and delivered with the gearbox together. Replace the breather plug with the most top plug according to your mounting position.



Some plug positions are not machined according mounting position. If no mounting position is mentioned by ordering the standard M1 position plugs are machined.

**6.7- Check the oil level ;**

On the mounting position tables the oil level plug is shown. Please refer to those tables and be sure that the oil level is correct according the mounting position by screwing half way out the level plug and see if oil comes out from that plug. If oil comes out tighten the plug again. If no oil comes out take out the filling plug and add oil until oil comes out from the level plug and tighten both plugs after finish. Be sure you are using the correct oil mentioned on the oil tables on this manual.



Do not mix synthetic oils with mineral which can cause serious damage on the gear unit.

**6.8- Check shaft ends and mounting faces;**

Before you start to installing be sure that all the connection elements are free of oil and dust. The output shaft may be protected by anti-corrosion oil. Please remove this using available solvents on your market. By using this do not touch sealing lips or painting of the housing.

**6.9- Cover abrasive ambient;**

If the gear unit will be placed on a abrasive ambient be sure that the output seals are covered so that no abrasive material, chemicals or water touches the seals. Any pressure coming from outside over the seals can cause that the out staying substances to enter the gearbox and cause serious damage to the gear unit. If pressure or abrasive material can not be prevented from coming over the sealing, contact YILMAZ REDUKTOR for solutions.



Abrasive material, chemicals, water, positive or negative pressure exceeding 0,2 bar can affect or damage the sealing lip or output shaft. Inside entering substances from the seals can cause serious damage to the gear unit.



**6.10- Check accessibility to filling, breather and drain plugs;**

The filling, breather and drain plugs must be freely accessible for further checking and service.

**7- Mechanical Installation**

The gear unit can only be installed using the supplied connection points like foot and flange assembling points.



*To install the gear unit without the supplied connection points can cause serious injuries by loosening or braking the gear unit. Even the gear unit is installed totally correctly according this manuel, be sure that no one will be harmed by accidentally brake downs or loosening.*



The mounting plate must be rigid enough not allowing torsions, flat enough to prevent strains by tightening the bolts and stable enough not allowing vibrations. By using chain drives this becomes much more important because of the polygon effect on chain drives. According to your connection elements the maximal permitted radial and axial load of the gear unit must be in accordance with your application. Check the product catalogue for permitted radial loads and calculation.



*If the output or input shaft is overloaded by radial or axial loads it can cause serious damage to the gear unit.*

Secure the gear unit using 8.8 or higher quality bolts.



***Cover all the turning parts from human entering or touching. Turning parts can cause severe or fatal injuries.***

For different kind of basic installations refer to the following illustrations.





**7.1- Assembling customer shaft with shrink disc**

**7.1.1- Loosen the bolts of the shrink disc**

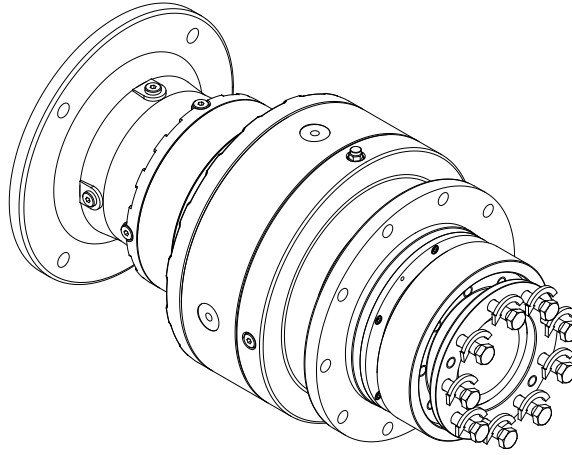

**7.1.2-** Use a solvent available in your market to clean all the dirt and oil from the shaft and shrink disc hollow. The surfaces must be free from oil or any dirt. The solvent must be removed from the surfaces as well.

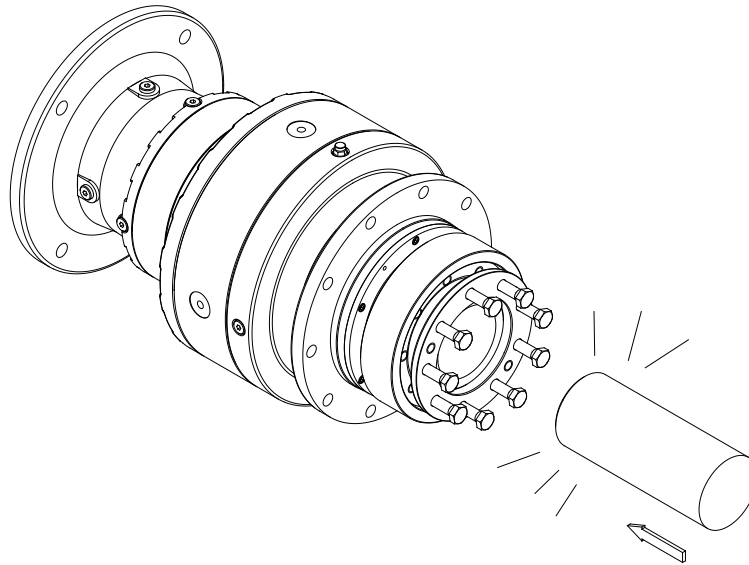



7.1.3- Insert the shaft and tighten the bolts as shown. Be sure that there is a clearance between the shrink disc shoulder and the hollow shaft shoulder of the gearbox.

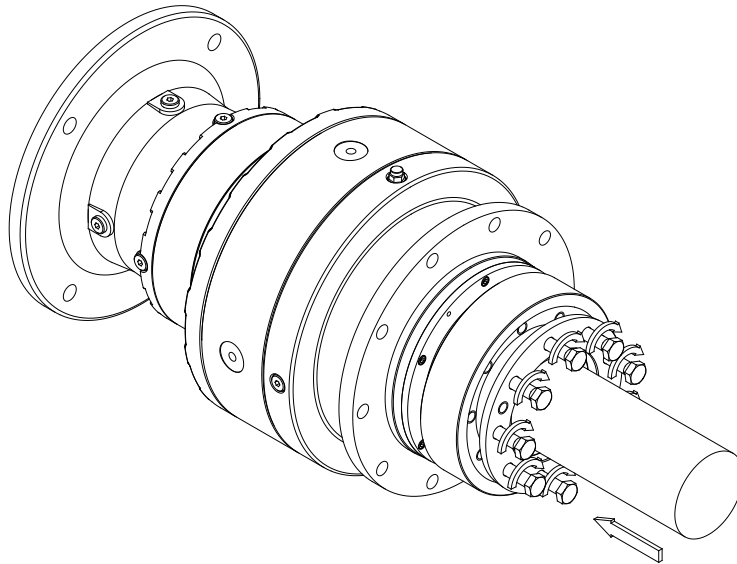

Type	Bolt	Tightening Torque [Nm]
P/R11..0S	M8	30
P/R12..0S	M8	30
P/R15..0S	M10	59
P/R16..0S	M10	59
P/R19..0S	M12	100
P/R23..0S	M14	160
P/R24..0S	M14	160
P/R27..0S	M16	250
P/R29..0S	M16	250
P/R35..0S	M16	250



**7.2- Disassembling customer shaft with shrink disc**

7.2.1- Loosen the bolts of the shrink disc and take out the shaft.

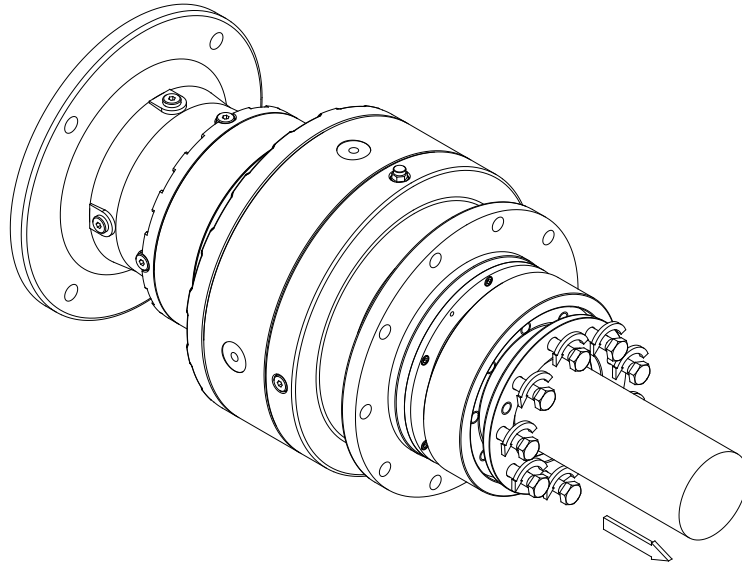



## 7.3 Assembling Gear Unit with Torque Arm

### 7.3.1- Dimensions

Torque arm dimension shown on below according to size of planetary gearbox.

#### One Sided Torque Arm

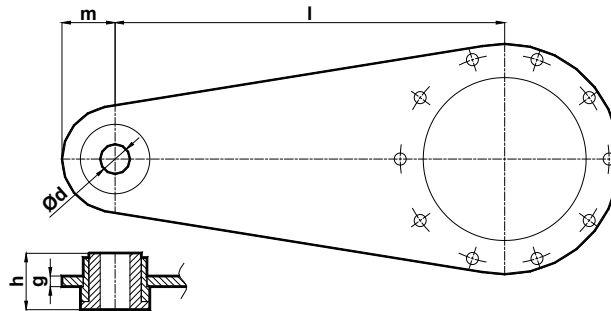

Type	l	m	d	h	g
P11/P12	300	60	21	60	12
P15/P16	350	60	32	60	15
P19	400	60	32	70	20
P23/P24	450	75	42	80	25
P27	700	90	52	100	25
P29	800	90	52	100	25
P35	900	120	72	120	30

#### Two Sided Torque Arm

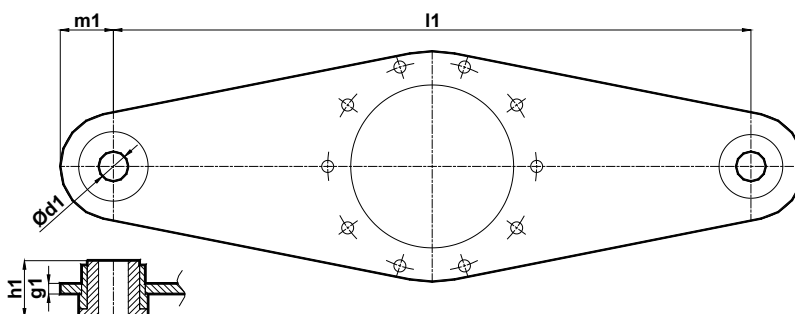

Type	l1	m1	d1	h1	g1
P11/P12	450	60	21	60	12
P15/P16	500	60	32	60	15
P19	600	60	32	70	20
P23/P24	700	75	42	80	25
P27	1000	90	52	100	25
P29	1100	90	52	100	25
P35	1200	120	72	120	30



7.3.2- Assemble the parts as shown bellow

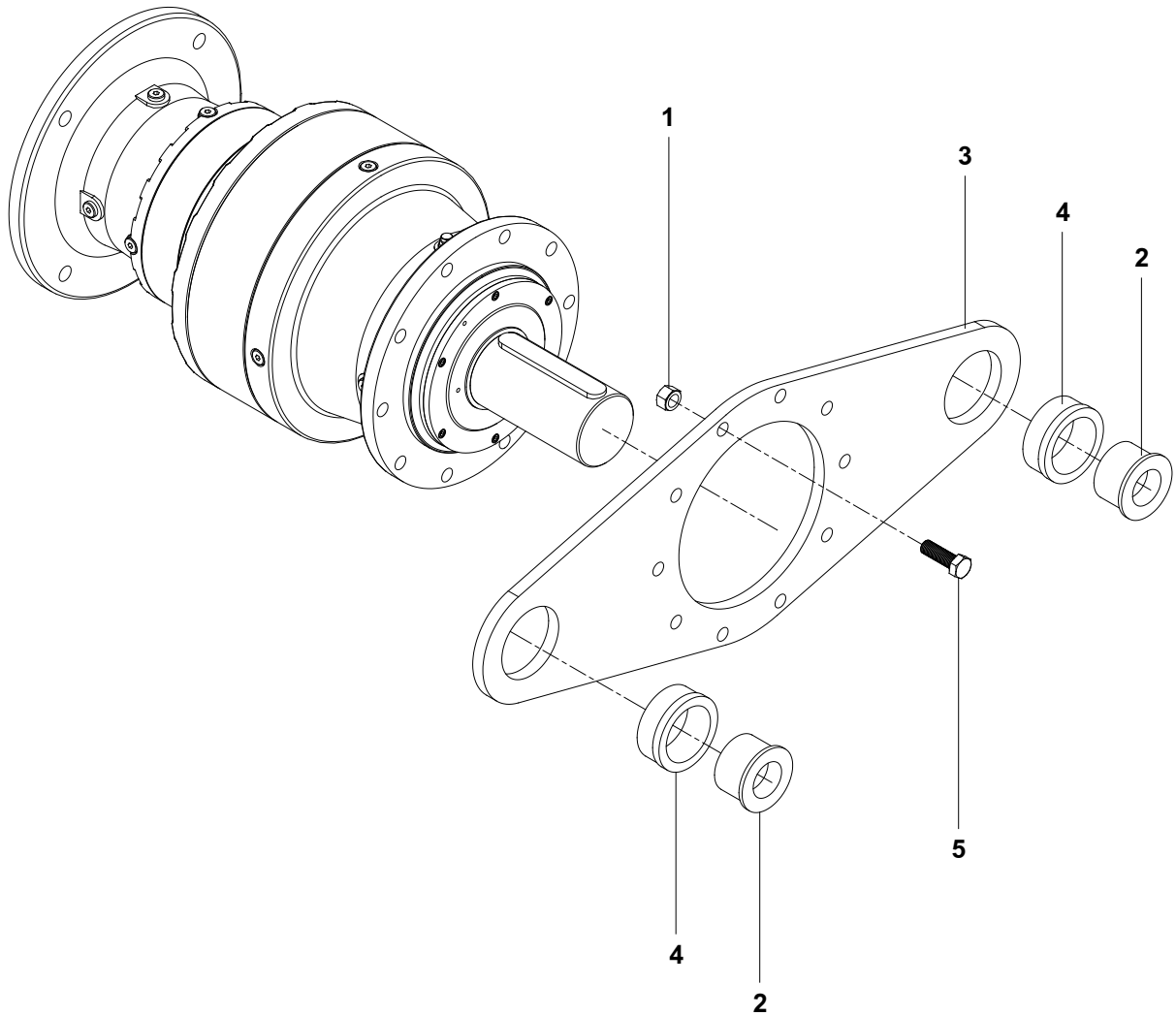

1- Nut	4- Torque arm
2- Rubber buffer	5- Bolt
3- Spacer	



**7.4 Fitting output shaft elements**

Use the following illustration to assemble output shaft units

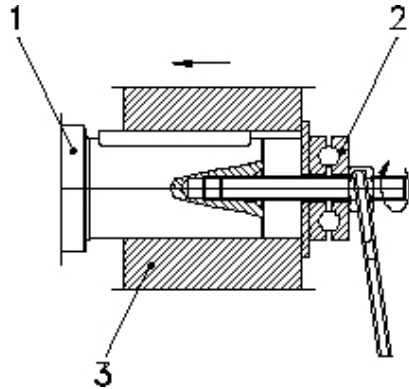

- 1) Gear shaft end
- 2) Thrust bearing
- 3) Coupling hub

**7.5- Correct position of output shaft elements**

The Output Shaft unit (transmission elements) must be placed as close as possible to the gear unit so that the radial load is as closest as possible to the gear unit.

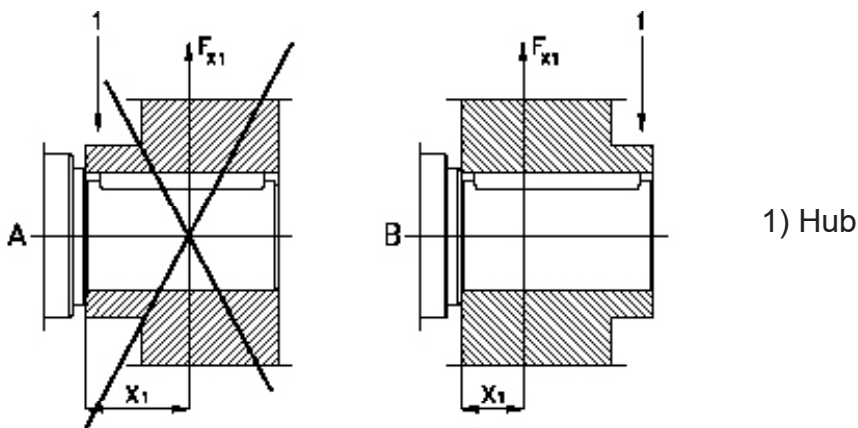

**7.6- Correct position of splined shaft output mounting positions**

Please refer the following mounting tolerances for splined output. Be sure that there is no eccentricity between axis.

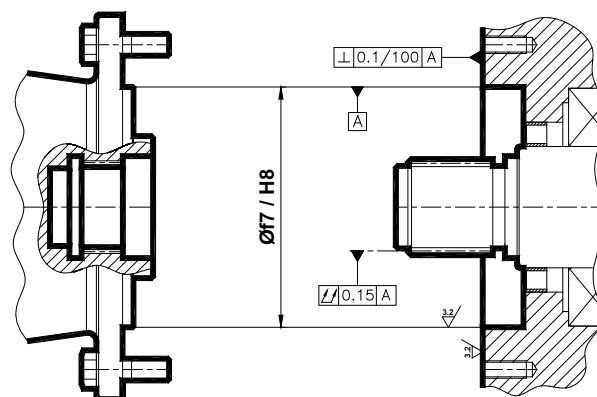



### 7.7- Fitting Couplings

7.7.1- By fitting couplings be sure that there is some clearance between the two elements

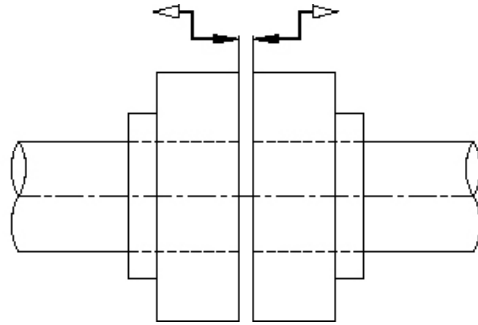

7.7.2- By fitting couplings be sure that there is no eccentricity between the two shafts.

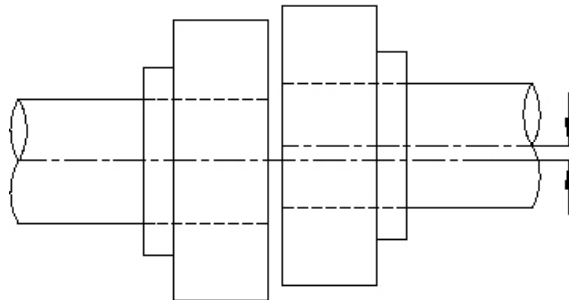

7.7.3- By fitting couplings be sure that the two shafts are not angular miss-aligned.

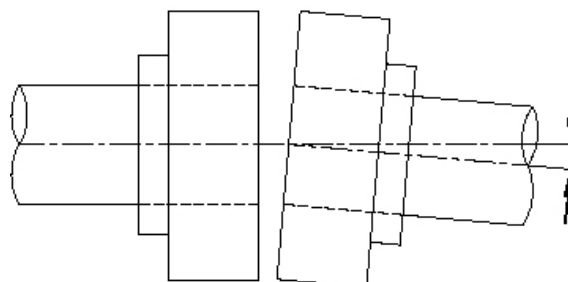



### 8- Maintenance and Inspections

Under normal ambient and working conditions the gear unit should be checked according the following intervals. (For definition of normal working conditions refer to the product catalogue: "Selecting Gearbox" section);

Item to check / replace	Every 3.000 operating hours or every 6 months	Every 10.000 operating Hours or every 3 years
Check for oil leakage	<b>x</b>	
Check for oil level	<b>x</b>	
Check oil leakage from seal	<b>x</b>	
Check Bearings Noise	<b>x</b>	
Change Mineral Oil		<b>x</b>
Change Sealing		<b>x(Change if necessary)</b>

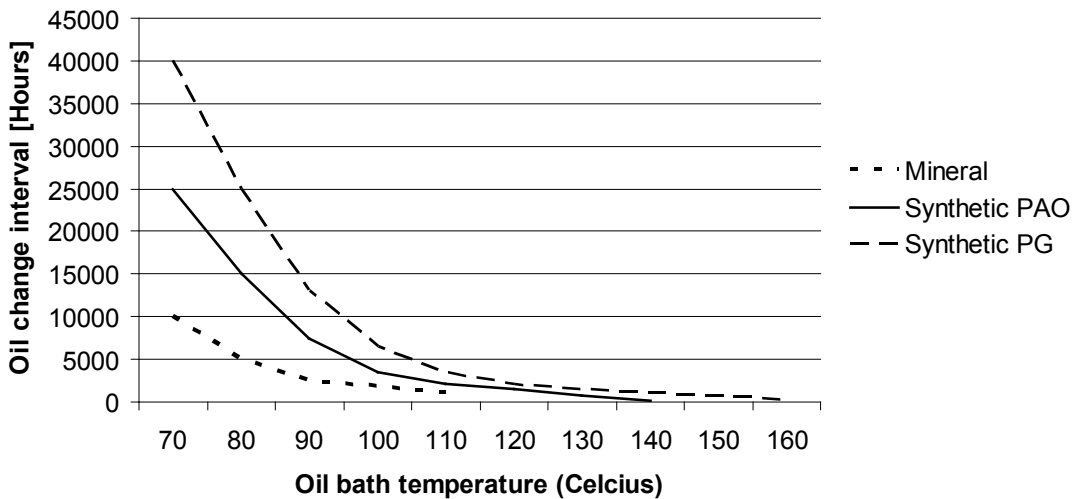

For normal ambient conditions 70 degrees Celsius oil bath temperature should be taken as reference

\* For P/R series mineral oil is used unless it is differently ordered. For oil type and quantities refer to the gear unit's label.



# Operating Instructions

## P/R Series

### Lubrication

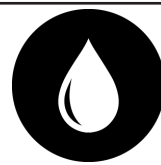

## 9- Lubrication

### 9-1 Oil Types

Lubricant	DIN 51517-3	Ambient Temperature [°C]		ISO VG	Beyond Petroleum	Castrol	Klüber Lubrication	Mobil	Shell
		Dip Lubrication	Forced Lubrication						
Mineral Oil	CLP	0 ... +50	–	680	Energol GR-XP 680	Alpha SP 680	Klüberoil GEM 1-680 N	Mobilgear XMP 680	Omala 680
		-5 ... +45	–	460	Energol GR-XP 460	Alpha SP 460	Klüberoil GEM 1-460 N	Mobilgear XMP 460	Omala F460
		-10 ... +40	+15 ... +40	320	Energol GR-XP 320	Alpha SP 320	Klüberoil GEM 1-320 N	Mobilgear XMP 320	Omala F320
		-15 ... +30	+10 ... +30	220	Energol GR-XP 220	Alpha SP 220	Klüberoil GEM 1-220 N	Mobilgear XMP 220	Omala F220
		-20 ... +20	+5 ... +20	150	Energol GR-XP-150	Alpha SP 150	Klüberoil GEM1-150 N	Mobilgear XMP150	Omala 150
		-25... +10	+3 ... +10	100	Energol GR-XP 100	Alpha SP 100	Klüberoil GEM 1-100 N	–	Omala 100
Synthetic Oil	CLP PG	-10 ... +60	–	680	Energysyn SG-XP 680	–	Klübersynth GH 6 -680	Mobil Glygoyle 680	Tivela S 680
		-20 ... +50	–	460	Energysyn SG-XP460	Aphasyn PG460	Klübersynth GH 6-460	Mobil Glygoyle 460	Tivela S 460
		-25 ... +40	+5 ... +40	320	Energysyn SG-XP320	Aphasyn PG320	Klübersynth GH 6-320	Mobil Glygoyle 320	Tivela S 320
		-30 ... +30	0 ... +30	220	Energysyn SG-XP 220	Aphasyn PG 220	Klübersynth GH 6-220	–	Tivela S 220
		-35 ... +20	-5 ... +20	150	Energysyn SG-XP 150	Aphasyn PG 150	Klübersynth GH 6 -150	–	Tivela S 150
		-40 ... +10	-8 ... +10	100	–	–	Klübersynth GH 6 -100	–	–
	CLP HC	-10 ... +60	–	680	–	–	Klübersynth GEM4-680 N	Mobilgear SHCXMP680	–
		-20 ... +50	–	460	Energysyn EP-XF 460	Alphasyn T 460	Klübersynth GEM4-460 N	Mobilgear SHC XMP460	Omala HD 460
		-25 ... +40	+5 ... +40	320	Energysyn EP-XF 320	Alphasyn T 320	Klübersynth GEM4-320 N	Mobilgear SHC XMP 320	Omala HD 320
		-30 ... +30	0 ... +30	220	Energysyn EP-XF 220	Alphasyn T 220	Klübersynth GEM4-220 N	Mobilgear SHC XMP 220	Omala HD 220
		-35 ... +20	-5 ... +20	150	Energysyn EP-XF 150	Alphasyn T 150	Klübersynth GEM4-150 N	Mobilgear SHC XMP 150	Omala HD 150
		-40 ... +10	-8 ... +10	100	–	–	Klübersynth GEM4-100 N	–	–
Food Grade Oil	CLP NSF H1	-15 ... +25	+5 ... +25	320	–	Optileb GT 320	Klüberoil 4 UH1-320 N	Mobil SHC Cibus 320	Cassida Fluid GL-320
Biodegradable Oil	CLP E	-25 ... +40	+5 ... +40	320	–	Tribol BioTop 1418-320	Klübersynth GEM 2-320	–	–
Mineral Grease [ -20 .... +120 Working Temperature °C ]					Energrease LS 3	Spheerol AP3	Centoplex 2 EP	Mobilux EP 3	Alvania RL3
Synthetic Grease [ -30 .... +100 Working Temperature °C ]					Energrease SY 2202	–	Petamo GHY 133 N	Mobiltemp SHC100	Cassida RLS 2

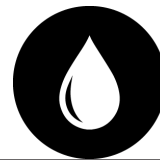

#### 9.2- Changing the oil



Refer to the nameplate to find out the correct oil filled inside the gearbox.

-Do not mix synthetic oils with mineral oils which will cause serious damage to the gear unit. The oil change must be done by using the filling, draining and level plugs according the mounting position illustrated in section 9.3.



- Extended, intensive contact with oils can lead to skin irritations. Avoid extended contact with oil, and clean oil off skin thoroughly.

- Hot oil can cause scalding. When changing oil, protect yourself against contacting hot oil.

#### 9.3 Mounting Positions

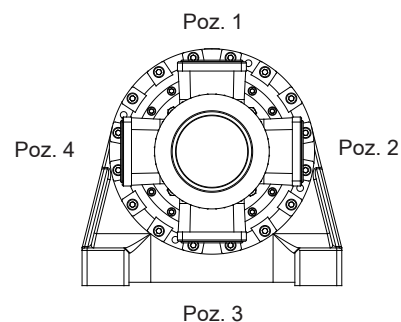
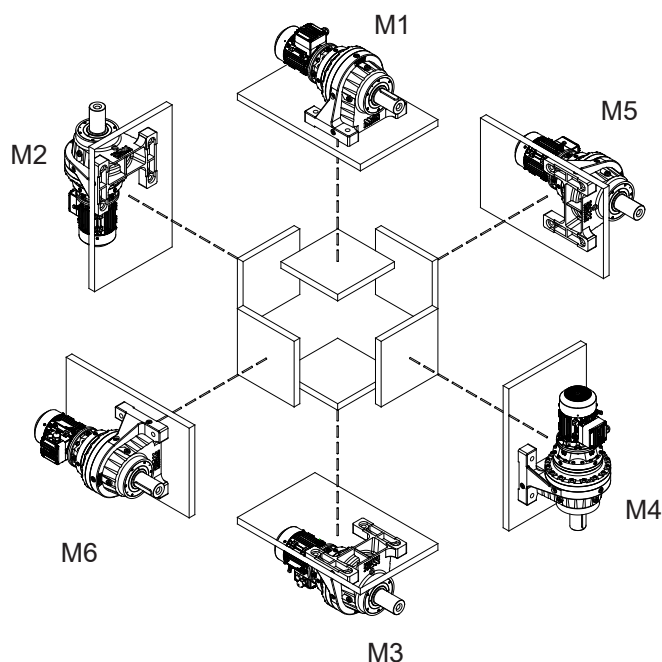
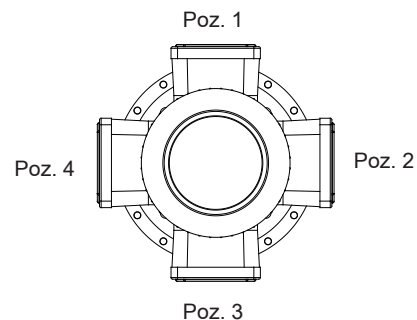
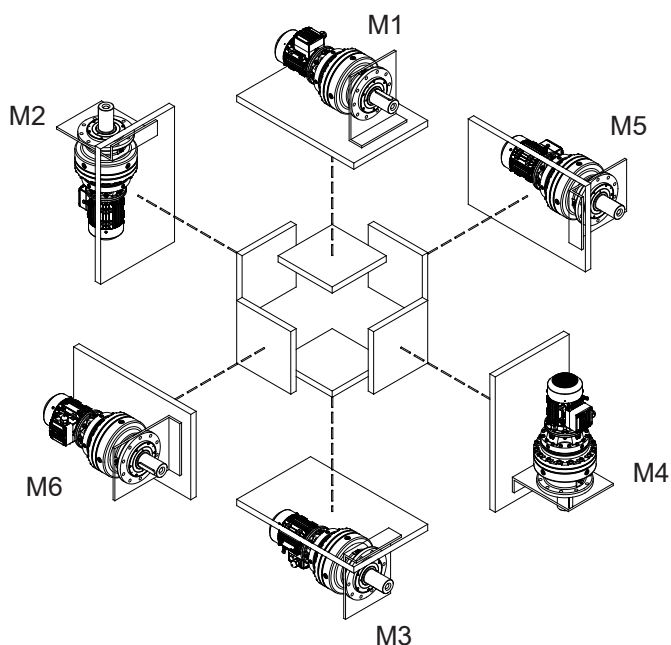



#### 9.3.1 Mounting Position P Series with K Form

**M1**

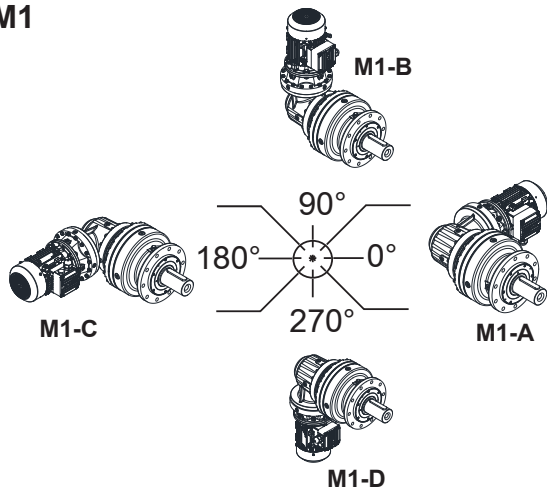

**M2**

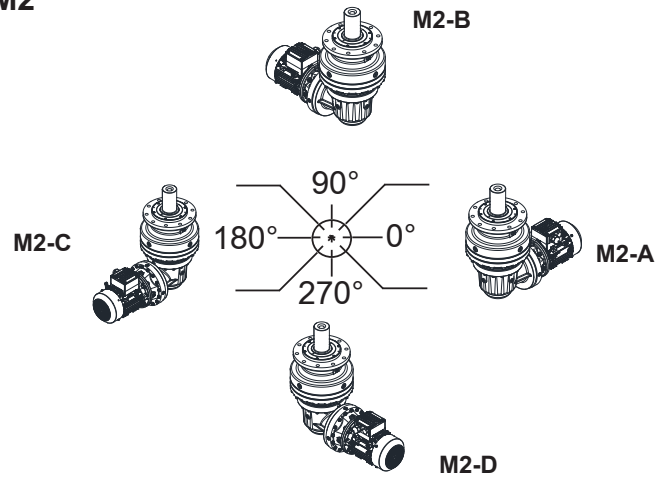

**M3**

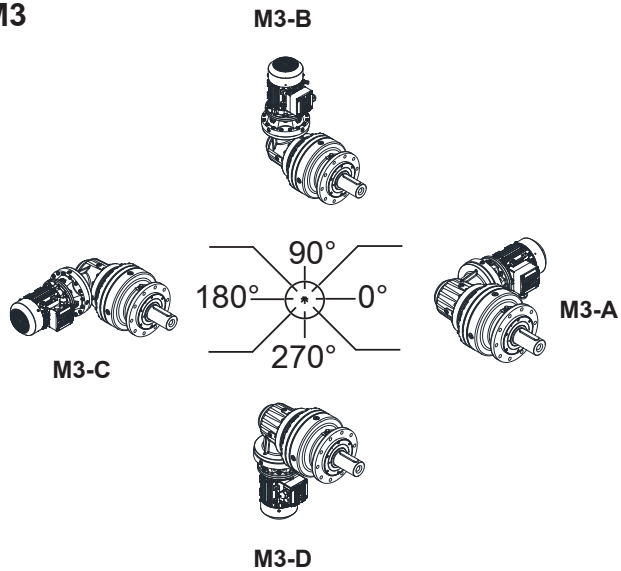

**M4**

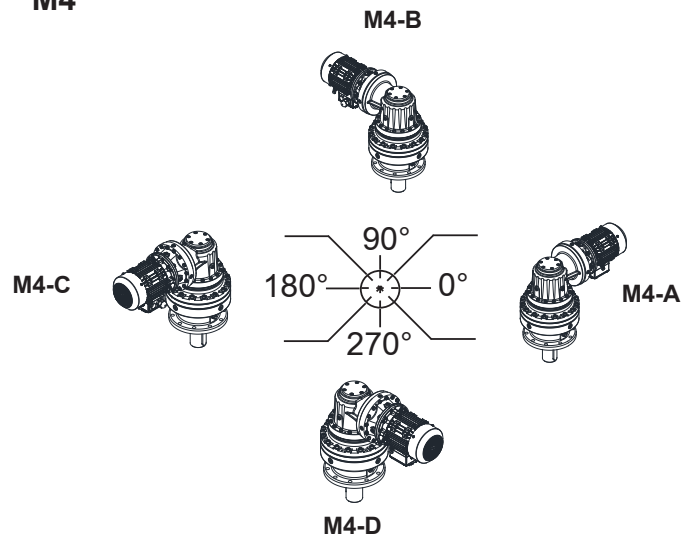

**M5**

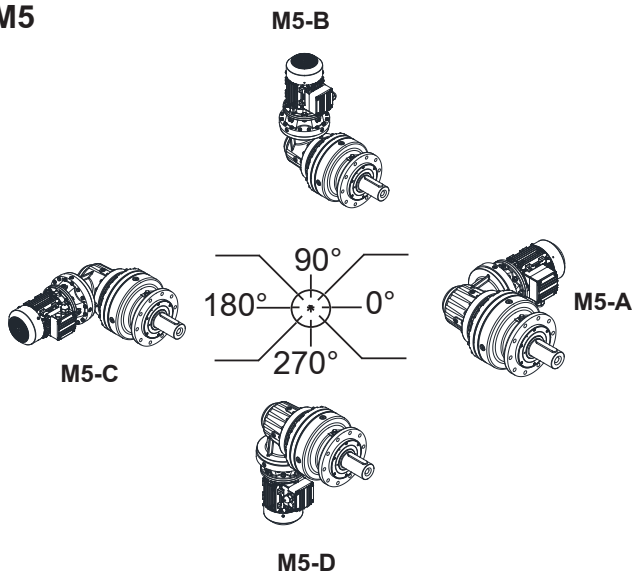

**M6**

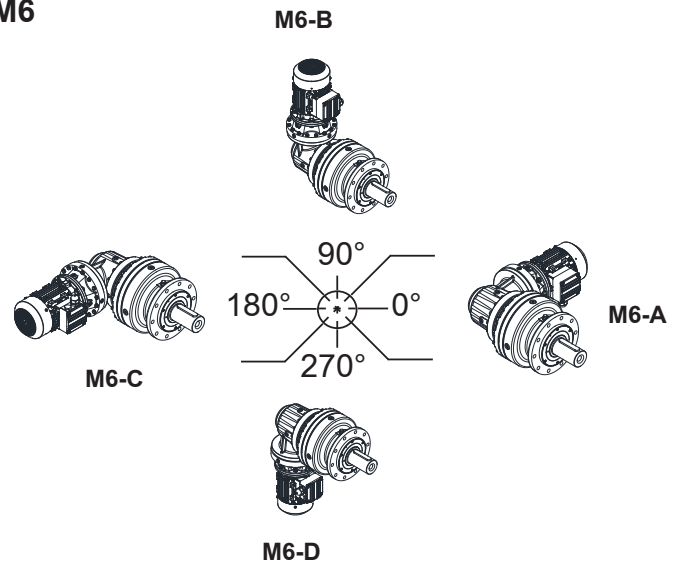



#### 9.3.2 Mounting Positions R Series with K Form

**M1**

**M1-B**

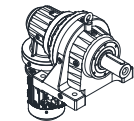
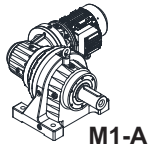
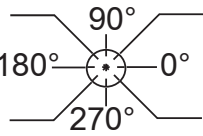
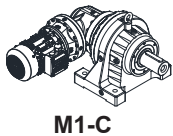
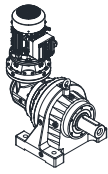

**M1-D**

**M2**

**M2-B**

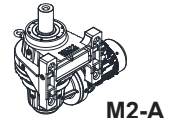
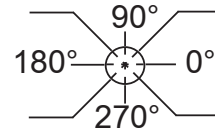
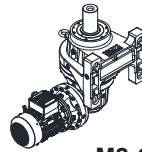
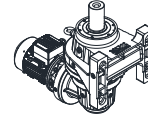

**M2-A**

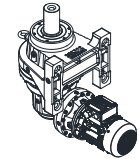

**M2-D**

**M3**

**M3-B**

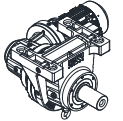
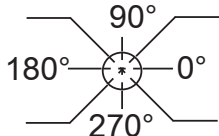
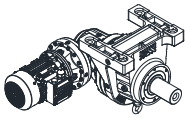
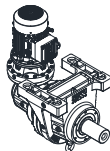

**M3-A**

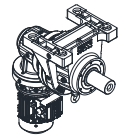

**M3-D**

**M4**

**M4-B**

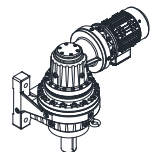
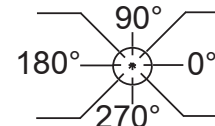
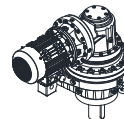
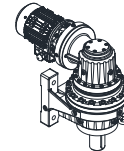

**M4-A**

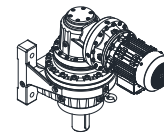

**M4-D**

**M5**

**M5-B**

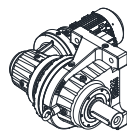
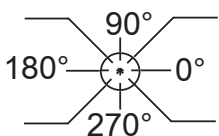
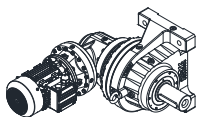
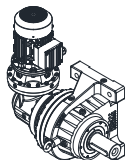

**M5-A**

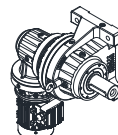

**M5-D**

**M6**

**M6-B**

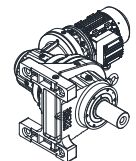
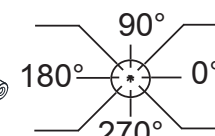
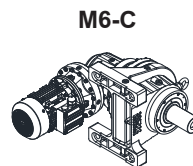
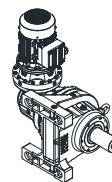

**M6-A**

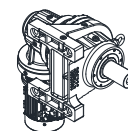

**M6-D**

# Operating Instructions

## P/R Series

### Lubrication



#### 9.3.3 Mounting Position for P Series Combined with Worm Gear

**M1**

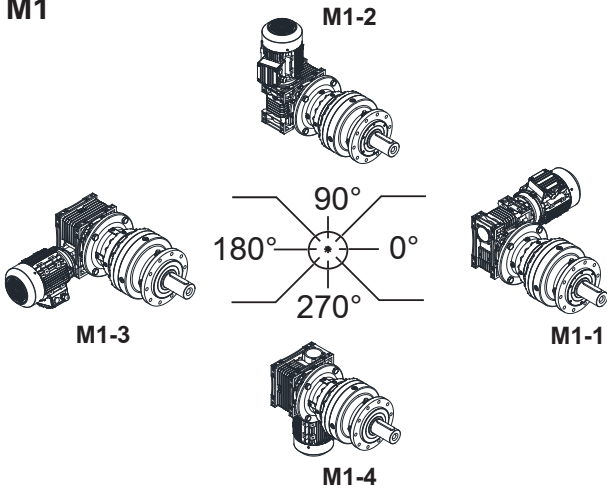

**M2**

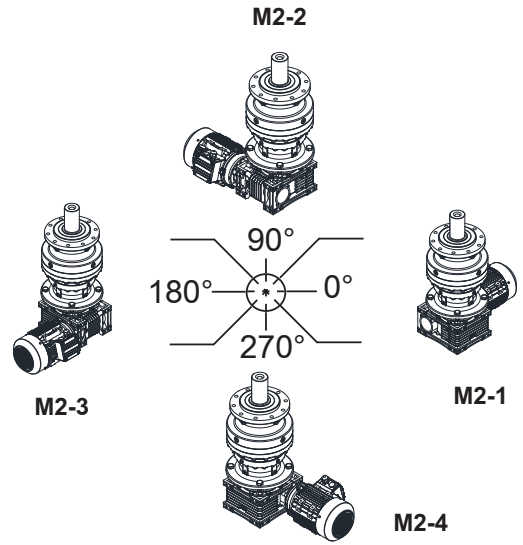

**M3**

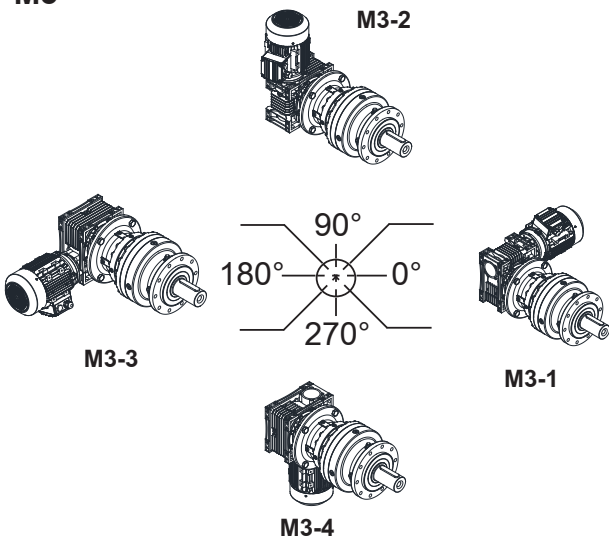

**M4**

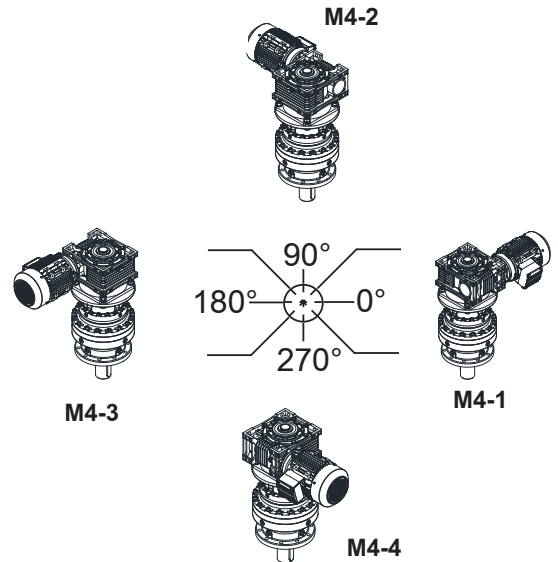

**M5**

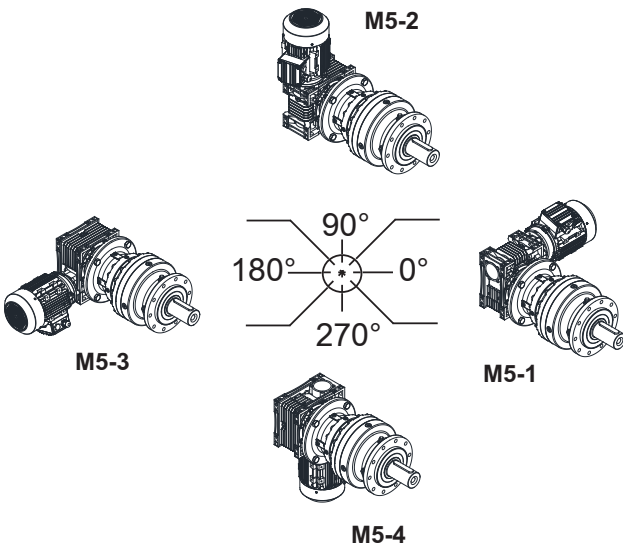

**M6**

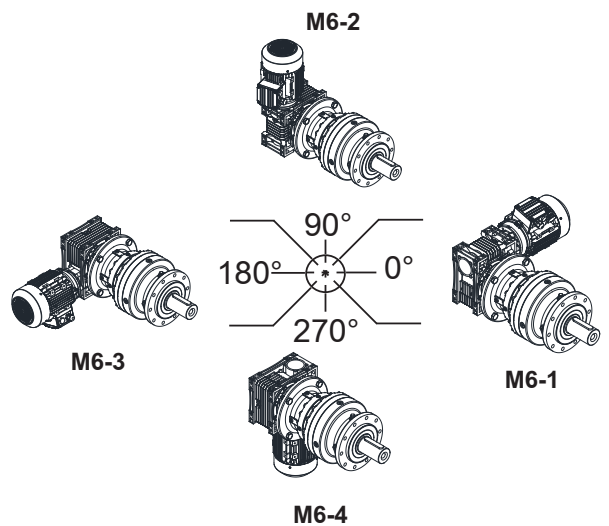





#### 9.3.4 Mounting Position for R Series Combined with Worm Gear

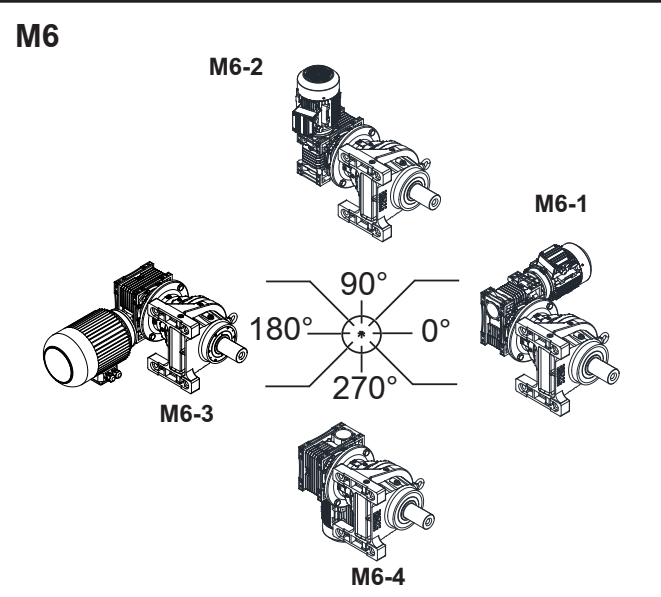
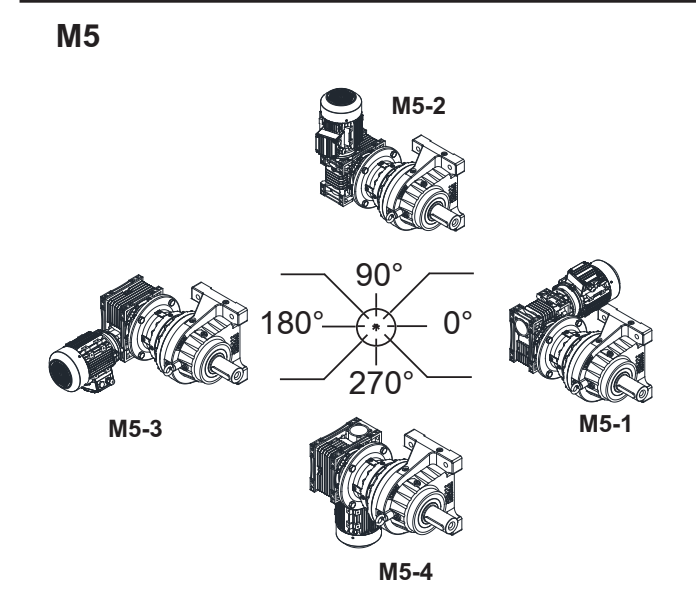
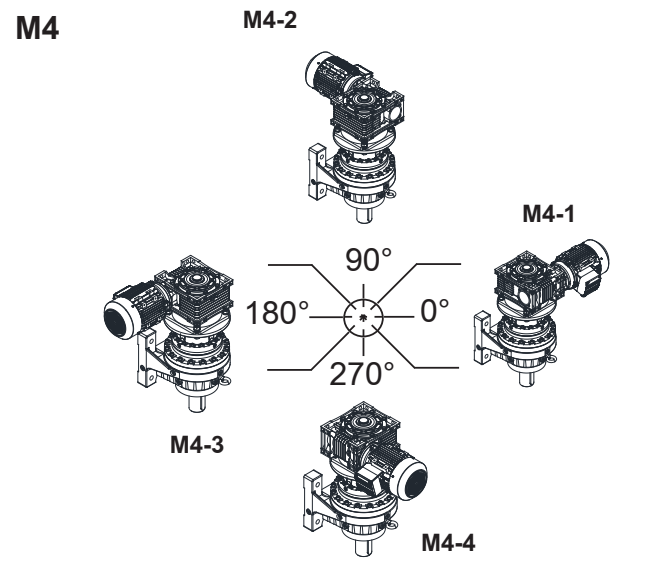
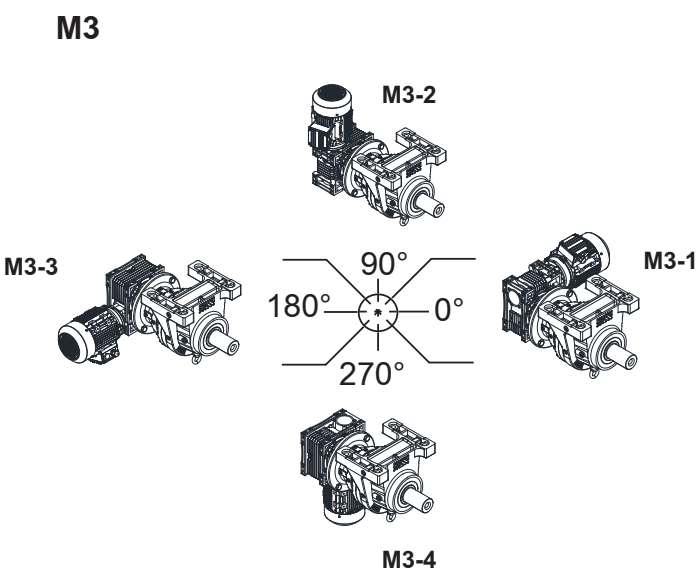
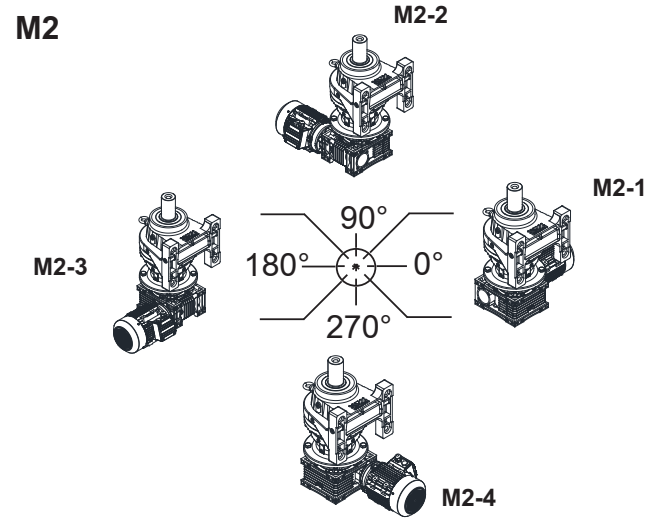
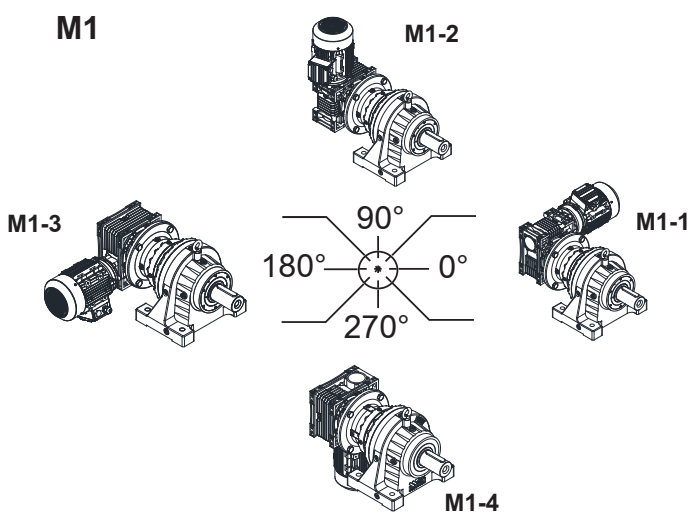

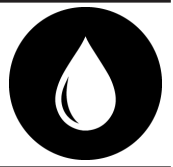

**9.4 Oil Quantities [liter]**

Gearbox Type	Mounting position					
	M1	M2	M3	M4	M5	M6
P.1101L / R.1101L	0,6	0,6	0,6	0,8	0,6	0,6
P.1102L / R.1102L	1,0	1,2	0,7	1,3	0,7	0,7
P.1103L / R.1103L	1,1	1,8	1,1	1,6	1,1	1,1
P.1104L / R.1104L	1,6	2,1	1,4	2,2	1,4	1,4
P.1201L / R.1201L	0,7	0,7	0,7	0,9	0,7	0,7
P.1202L / R.1202L	0,8	1,3	0,8	0,9	0,8	0,8
P.1203L / R.1203L	1,5	2,0	1,5	1,8	1,5	1,5
P.1204L / R.1204L	1,5	2,3	1,5	2,4	1,5	1,5
P.1501L / R.1501L	1,4	2,8	1,4	1,7	1,4	1,4
P.1502L / R.1502L	1,3	1,9	1,3	2,1	1,3	1,3
P.1503L / R.1503L	1,5	2,4	1,5	2,6	1,5	1,5
P.1504L / R.1504L	1,8	3,0	1,8	3,1	1,8	1,8
P.1601L / R.1601L	1,5	3,0	1,5	1,9	1,5	1,5
P.1602L / R.1602L	1,5	2,1	1,5	2,2	1,5	1,5
P.1603L / R.1603L	1,8	2,6	1,8	2,8	1,8	1,8
P.1604L / R.1604L	2,0	3,0	2,0	3,2	2,0	2,0
P.1901L / R.1901L	2,2	2,4	2,2	2,2	2,2	2,2
P.1902L / R.1902L	2,0	2,9	2,0	3,3	2,0	2,0
P.1903L / R.1903L	3,4	2,1	1,8	3,1	1,8	1,8
P.1904L / R.1904L	2,0	2,5	2,0	3,5	2,0	2,0
P.2301L / R.2301L	3,6	4,2	3,6	4,2	3,6	3,6
P.2302L / R.2302L	4,3	4,2	4,3	7,2	4,3	4,3
P.2303L / R.2303L	4,1	3,7	3,4	6,4	3,4	3,4
P.2304L / R.2304L	3,6	4,2	3,6	6,8	3,6	3,6
P.2401L / R.2401L	4,0	4,9	4,0	4,5	4,0	4,0
P.2402L / R.2402L	4,5	4,4	4,5	7,4	4,5	4,5
P.2403L / R.2403L	3,5	4,0	3,5	6,5	3,5	3,5
P.2404L / R.2404L	5,5	4,4	4,0	7,0	4,0	4,0
P.2701L / R.2701L	4,3	9,0	4,3	8,6	4,3	4,3
P.2702L / R.2702L	4,7	8,3	4,7	7,1	4,7	4,7
P.2703L / R.2703L	4,8	10,75	7,3	6,7	7,3	7,3
P.2704L / R.2704L	4,9	8,5	4,7	8,5	4,7	4,7
P.2901L / R.2901L	5,75	8,3	5,75	9,65	5,75	5,75
P.2902L / R.2902L	6,05	11,15	6,05	7,55	6,05	6,05
P.2903L / R.2903L	6,1	8,8	6,1	10,35	6,1	6,1
P.2904L / R.2904L	6,2	8,7	6,2	11,75	6,2	6,2
P.3501L / R.3501L	6,5	7,6	6,5	10,7	6,5	6,5
P.3502L / R.3502L	7,4	14,0	7,4	8,0	7,4	7,4
P.3503L / R.3503L	9	8,6	9	24	9	9
P.3504L / R.3504L	12,3	8,9	12,3	15,0	12,3	12,3



#### 9.4 Oil Quantities [liter]

Gearbox Types	Mounting position					
	M1-A	M2-A	M3-A	M4-A	M5-A	M6-A
P.1102K / R.1102K	1,3	2,3	1,3	1,7	1,3	1,3
P.1103K / R.1103K	1,6	3	1,6	2,2	1,6	1,6
P.1104K / R.1104K	2,4	4,5	2,4	3,1	2,4	2,4
P.1202K / R.1202K	1,4	2,5	1,4	1,8	1,4	1,4
P.1203K / R.1203K	1,7	3,2	1,7	2,3	1,7	1,7
P.1204K / R.1204K	2,5	4,7	2,5	1,8	2,5	2,5
P.1502K / R.1502K	2,1	4,8	2,1	2,4	2,1	2,1
P.1503K / R.1503K	2	3,1	2	3	2	2
P.1504K / R.1504K	2	2,6	2	3,9	2	2
P.1602K / R.1602K	2,2	4,9	2,2	2,5	2,2	2,2
P.1603K / R.1603K	2,1	2,5	2,1	3,1	2,1	2,1
P.1604K / R.1604K	2,1	2,7	2,1	4	2,1	2,1
P.1902K / R.1902K	5	8,2	5	6,1	5	5
P.1903K / R.1903K	3,1	4,7	3,1	5	3,1	3,1
P.1904K / R.1904K	2,8	3	2,8	4,8	2,8	2,8
P.2302K / R.2302K	7,1	10,6	7,1	9,6	7,1	7,1
P.2303K / R.2303K	4,2	5,2	4,2	7,2	4,2	4,2
P.2304K / R.2304K	4,1	4,0	4,1	7,3	4,1	4,1
P.2402K / R.2402K	7,2	10,7	7,2	9,7	7,2	7,2
P.2403K / R.2403K	4,3	5,3	4,3	7,3	4,3	4,3
P.2404K / R.2404K	4,2	4,1	4,2	7,4	4,2	4,2
P.2702K / R.2702K	11	14,4	11	12,2	11	11
P.2703K / R.2703K	3,1	7,6	3,1	9	3,1	3,1
P.2704K / R.2704K	5,3	6,4	5,3	9,5	5,3	5,3
P.2902K / R.2902K	11,6	15,8	11,6	13,4	11,6	11,6
P.2903K / R.2903K	6,6	10,4	6,6	11,8	6,6	6,6
P.2904K / R.2904K	6,7	7,8	6,7	8,8	6,7	6,7
P.3502K / R.3502K	12,1	17,2	12,1	14,5	12,1	12,1
P.3503K / R.3503K	10,2	13,1	10,2	14,5	10,2	10,2
P.3504K / R.3504K	8,1	9,2	8,1	8,2	8,1	8,1

PV1501K.01

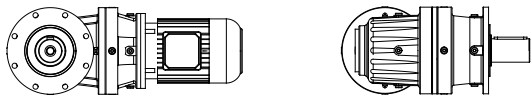

M1-A

PV1501K.01

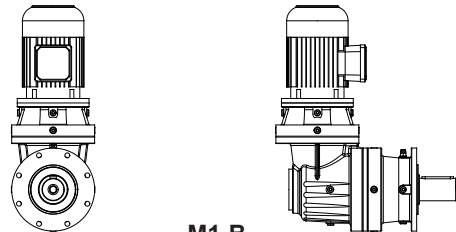

M1-B

PV1501K.01

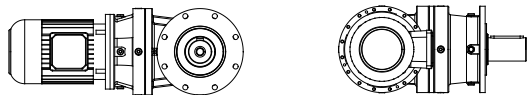

M1-C

PV1501K.01

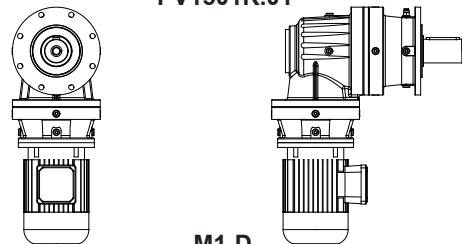

M1-D



# Operating Instructions

## P/R Series

### Lubrication



#### 9.4 Oil Quantities [liter]

Gearbox	Mounting position					
	M1-B	M2-B	M3-B	M4-B	M5-B	M6-B
P...1102K / R...1102K	1	2,3	1,25	1,7	1	1
P...1103K / R...1103K	1,2	3	1,6	2,2	1,2	1,2
P...1104K / R...1104K	3,6	4,5	2,4	3,0	3,6	3,6
P...1202K / R...1202K	1,1	2,4	1,4	1,8	1,1	1,1
P...1203K / R...1203K	1,3	3,1	1,7	2,3	1,3	1,3
P...1204K / R...1204K	3,7	4,6	2,6	3,1	3,7	3,7
P...1502K / R...1502K	1,8	4,8	2,1	2,4	1,8	1,8
P...1503K / R...1503K	1,7	3,1	2	3	1,7	1,7
P...1504K / R...1504K	1,7	2,6	1,7	3,9	1,7	1,7
P...1602K / R...1602K	1,9	4,9	2,2	2,5	1,9	1,9
P...1603K / R...1603K	1,8	3,2	2,1	3,1	1,8	1,8
P...1604K / R...1604K	1,8	2,7	1,77	4,0	1,8	1,8
P...1902K / R...1902K	3,9	8,2	3,9	6,1	3,9	3,9
P...1903K / R...1903K	5,2	4,7	5,22	5	5,2	5,2
P...1904K / R...1904K	2,5	3	2,5	4,8	2,5	2,5
P...2302K / R...2302K	7,1	10,6	6,1	9,1	6,1	6,1
P...2303K / R...2303K	4	5,2	4,4	7,2	4	4
P...2304K / R...2304K	3,8	4,0	4,1	7,3	3,8	3,8
P...2402K / R...2402K	7,2	10,7	6,2	9,2	6,2	6,2
P...2403K / R...2403K	4,1	5,3	4,5	7,3	4,1	4,1
P...2404K / R...2404K	3,9	4,1	4,9	7,4	3,9	3,9
P...2702K / R...2702K	9,3	14,4	9,3	12,2	9,3	9,3
P...2703K / R...2703K	4,9	7,6	4,9	9,2	4,9	4,9
P...2704K / R...2704K	5	6,4	5,3	9,51	5	5
P...2902K / R...2902K	8	15,8	8	13,4	8	8
P...2903K / R...2903K	7,1	10,3	7,1	11,8	7,1	7,1
P...2904K / R...2904K	6,5	7,8	6,6	8,8	6,5	6,5
P...3502K / R...3502K	6,8	17,2	6,7	14,5	6,8	6,8
P...3503K / R...3503K	9,2	13,1	9,2	14,5	9,2	9,2
P...3504K / R...3504K	7,9	9,2	7,9	8,2	7,9	7,9

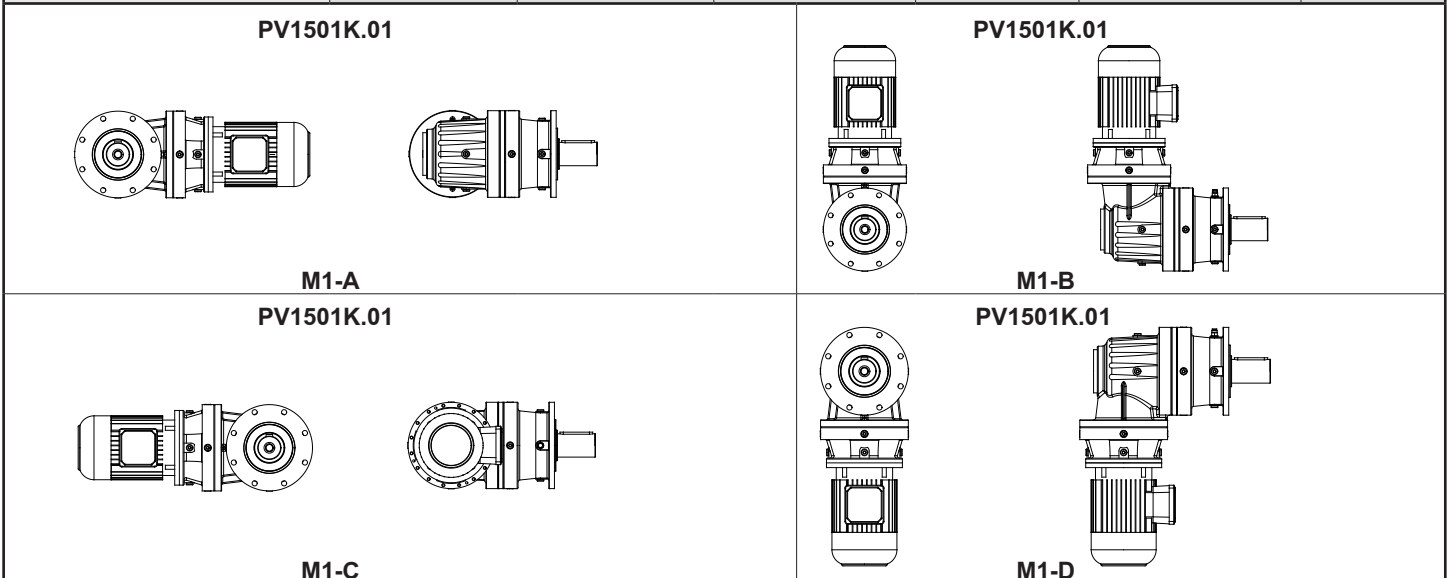



#### 9.4 Oil Quantities [liter]

Gearbox	Mounting position					
	M1-C	M2-C	M3-C	M4-C	M5-C	M6-C
P...1102K / R...1102K	1,3	2,3	1,25	1,7	1,3	1,3
P...1103K / R...1103K	1,6	3	1,6	2,2	1,6	1,6
P...1104K / R...1104K	2,4	4,5	2,4	3,0	2,4	2,4
P...1202K / R...1202K	1,4	2,4	1,4	1,8	1,4	1,4
P...1203K / R...1203K	1,7	3,1	1,7	2,3	1,7	1,7
P...1204K / R...1204K	2,5	4,6	2,5	3,1	2,5	2,5
P...1502K / R...1502K	2,1	4,8	2,1	2,4	2,1	2,1
P...1503K / R...1503K	2	3,1	2	3	2	2
P...1504K / R...1504K	2	2,6	1,7	3,9	2	2
P...1602K / R...1602K	2,21	4,9	2,2	2,5	2,2	2,2
P...1603K / R...1603K	2,1	3,2	2,1	3,1	2,1	2,1
P...1604K / R...1604K	2,1	2,7	1,77	4,0	2,1	2,1
P...1902K / R...1902K	5	8,2	3,9	6,1	5	5
P...1903K / R...1903K	3,1	4,7	5,2	5	3,1	3,1
P...1904K / R...1904K	2,8	3	2,5	4,8	2,8	2,8
P...2302K / R...2302K	7,1	10,6	6,1	9,6	7,1	7,1
P...2303K / R...2303K	4	5,2	4,4	7,2	4	4
P...2304K / R...2304K	4,1	4,0	4,1	7,3	4,1	4,1
P...2402K / R...2402K	7,2	10,7	6,2	9,7	7,2	7,2
P...2403K / R...2403K	4,1	5,3	4,5	7,3	4,1	4,1
P...2404K / R...2404K	4,2	4,1	4,2	7,4	4,2	4,2
P...2702K / R...2702K	11	14,4	9,3	12,2	11	11
P...2703K / R...2703K	3,1	7,6	4,9	9,2	3,1	3,1
P...2704K / R...2704K	5,3	6,4	5,3	9,5	5,3	5,3
P...2902K / R...2902K	12,6	15,8	11,8	13,4	12,6	12,6
P...2903K / R...2903K	6,6	10,3	7,04	11,8	6,6	6,6
P...2904K / R...2904K	6,4	7,8	6,6	8,8	6,4	6,4
P...3502K / R...3502K	14,2	17,2	14,2	14,5	14,2	14,2
P...3503K / R...3503K	10,2	13,1	9,2	14,5	10,2	10,2
P...3504K / R...3504K	7,5	9,2	7,9	8,16	7,5	7,5

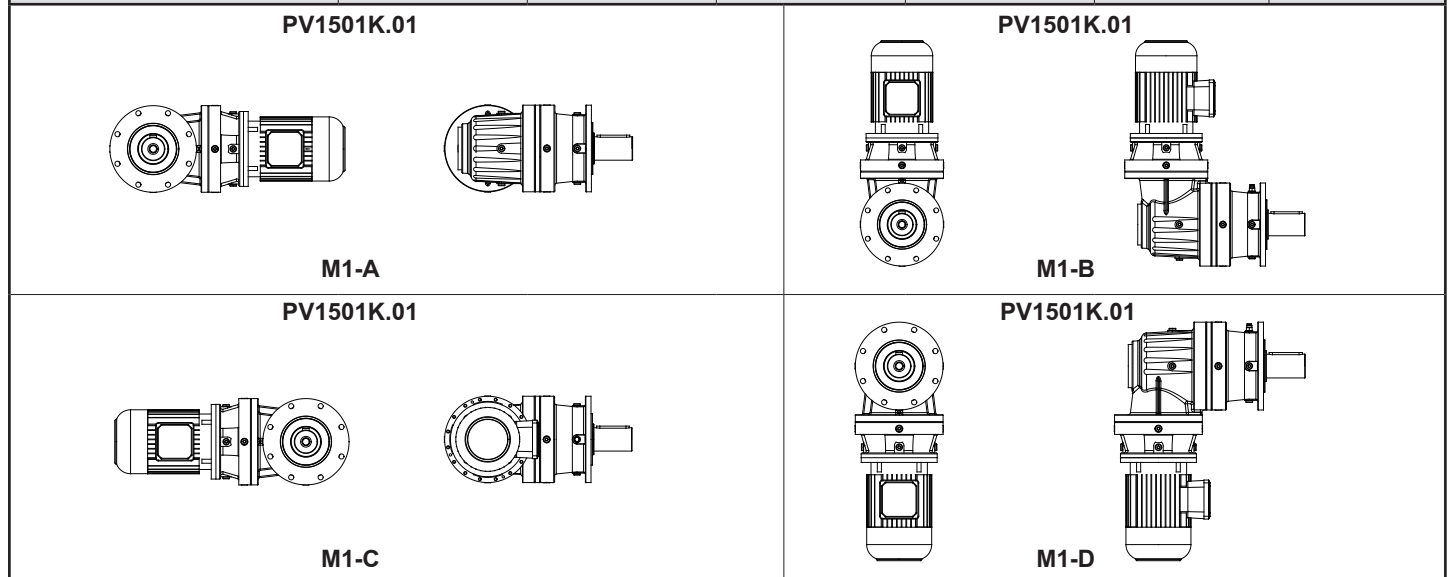

# Operating Instructions

## P/R Series

### Lubrication



#### 9.5 Oil Plugs

##### 9.5.1 Oil Plugs for P Series L Type

Mounting position	Single Stage	2 Stages	3 Stages	4 Stages
M1				
M2				
M3				
M4				
M5				
M6				

Symbol :

■ : Drain Plug

▽ : Oil Filling

▼ : Oil Level

● : Breather



9.5.2 Oil Plugs for R Series L Type

Mounting position	Single Stage	2 Stages	3 Stages	4 Stages
M1				
M2				
M3				
M4				
M5				
M6				

Symbol : : Drain Plug      : Oil Filling      : Oil Level      : Breather



#### 9.5.3 Oil Plugs for P Series K Type

Mounting position	A	B	C	D
M1				
M2				
M3				
M4				
M5				
M6				

Symbol :

■ : Drain Plug

▽ : Oil Filling

▼ : Oil Level

● : Breather



**9.5.4 Oil Plugs for R Series K Type**

Mounting position	A	B	C	D
M1				
M2				
M3				
M4				
M5				
M6				

Symbol : : Drain Plug      : Oil Filling      : Oil Level      : Breather

# Operating Instructions

## P/R Series

### Lubrication



#### 9.5.5 Oil Plugs for P Series Gearboxes Combined with E Series

Mounting position	1	2	3	4
M1				
M2				
M3				
M4				
M5				
M6				

Symbol : : Drain Plug      : Oil Filling      : Oil Level      : Breather





#### 9.5.6 Oil Plugs for R Series Gearboxes Combined with E Series

Mounting position	1	2	3	4
M1				
M2				
M3				
M4				
M5				
M6				

Symbol : :Drain Plug :Oil Filling :Oil Level :Breather



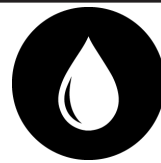

**9.6 Oil Expansion Tank:**

Expansion tanks can be used with Planetary gearboxes according to mounting positions shown on below.

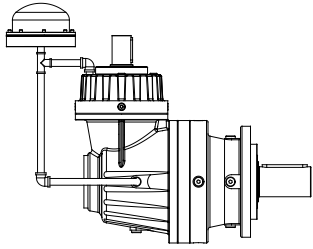
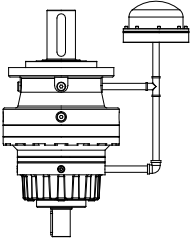
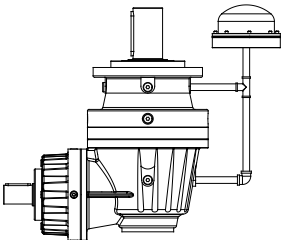
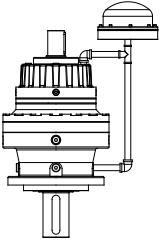
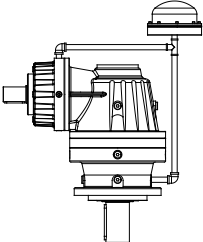
Mounting Pos.	Expansion Tank (L Type)	Expansion Tank (K Type)
M1	<b>Not Applicable</b>	
M2		
M3	<b>Not Applicable</b>	<b>Not Applicable</b>
M4		



## 10. Hydraulic Motors

All motors must be charged with hydraulic fluid before being operated and during installation. You can find the technical information and picture below. Performance diagrams or other detailed informations please see the P / R series product catalogue or contact YILMAZ REDUKTOR.

Type	Geometric Displacement V [cm <sup>3</sup> /rev]	Maximum Speed [rpm]	Max. Oil Flow Q [l/min]	Max. Pressure Difference [Bar]	Max Supply Pressure [bar]	Maximum Torque [Nm] (cont / int)	Maximum Power [kW]	Min. Starting Torque [Nm]	
HE	HE 36	36	930 / 1160	35 / 42	140 / 190	200	55 / 70	8,5	44 / 52
	HE 45	41	810 / 990	35 / 42	140 / 190	200	70 / 100	10	44 / 64
	HE 50	50	725 / 935	35 / 45	140 / 175	200	90 / 115	11	72 / 92
	HE 65	66	705 / 940	45 / 60	140 / 175	200	125 / 160	15	100 / 128
	HE 80	82	560 / 750	45 / 60	140 / 175	200	160 / 200	15	128 / 160
	HE 100	98	470 / 630	45 / 60	140 / 175	200	190 / 240	15	152 / 192
	HE 130	130	350 / 470	45 / 60	140 / 175	200	255 / 320	15	204 / 256
	HE 165	163	280 / 375	45 / 60	140 / 175	200	310 / 395	15	248 / 316
	HE 195	196	235 / 315	45 / 60	140 / 175	200	390 / 480	15	312 / 384
	HE 230	228	265 / 330	60 / 75	120 / 150	200	380 / 480	15	304 / 384
	HE 260	261	230 / 290	60 / 75	110 / 140	200	400 / 525	15	320 / 420
	HE 295	293	200 / 255	60 / 75	100 / 130	200	410 / 520	13	328 / 416
	HE 330	326	185 / 235	60 / 75	100 / 120	200	430 / 530	13	344 / 424
	HE 365	370	150 / 200	60 / 75	95 / 110	200	467 / 558	11	373 / 446
HE 390	392	152 / 190	60 / 75	85 / 100	200	435 / 540	10	348 / 432	
HG	HG 140	140	530 / 710	75 / 100	200 / 280	300	400 / 545	33	320 / 436
	HG 170	169	440 / 575	75 / 100	200 / 280	300	485 / 670	33	388 / 536
	HG 195	195	380 / 510	75 / 100	200 / 280	300	560 / 770	33	448 / 616
	HG 240	237	320 / 420	75 / 100	200 / 280	300	685 / 945	32	548 / 756
	HG 280	280	270 / 350	75 / 100	200 / 280	300	800 / 1100	31	640 / 880
	HG 335	337	225 / 290	75 / 100	200 / 280	300	980 / 1350	30	784 / 1080
	HG 405	405	185 / 245	75 / 100	170 / 240	300	960 / 1350	27	768 / 1080
	HG 475	476	160 / 240	75 / 115	140 / 200	300	960 / 1400	28	768 / 1120
	HG 530	529	140 / 215	75 / 115	140 / 170	300	1050 / 1280	23	840 / 1024
	HG 625	624	120 / 185	75 / 115	120 / 160	300	1040 / 1360	20	832 / 1088
	HG 785	786	95 / 145	75 / 115	100 / 140	300	1150 / 1490	17	920 / 1192
HG 960	958	78 / 119	75 / 115	70 / 100	300	925 / 1390	12	740 / 1112	

Intermittent operation rating applies to %10 of every minute.



10.1 HE Series flange and Shaft dimensions:

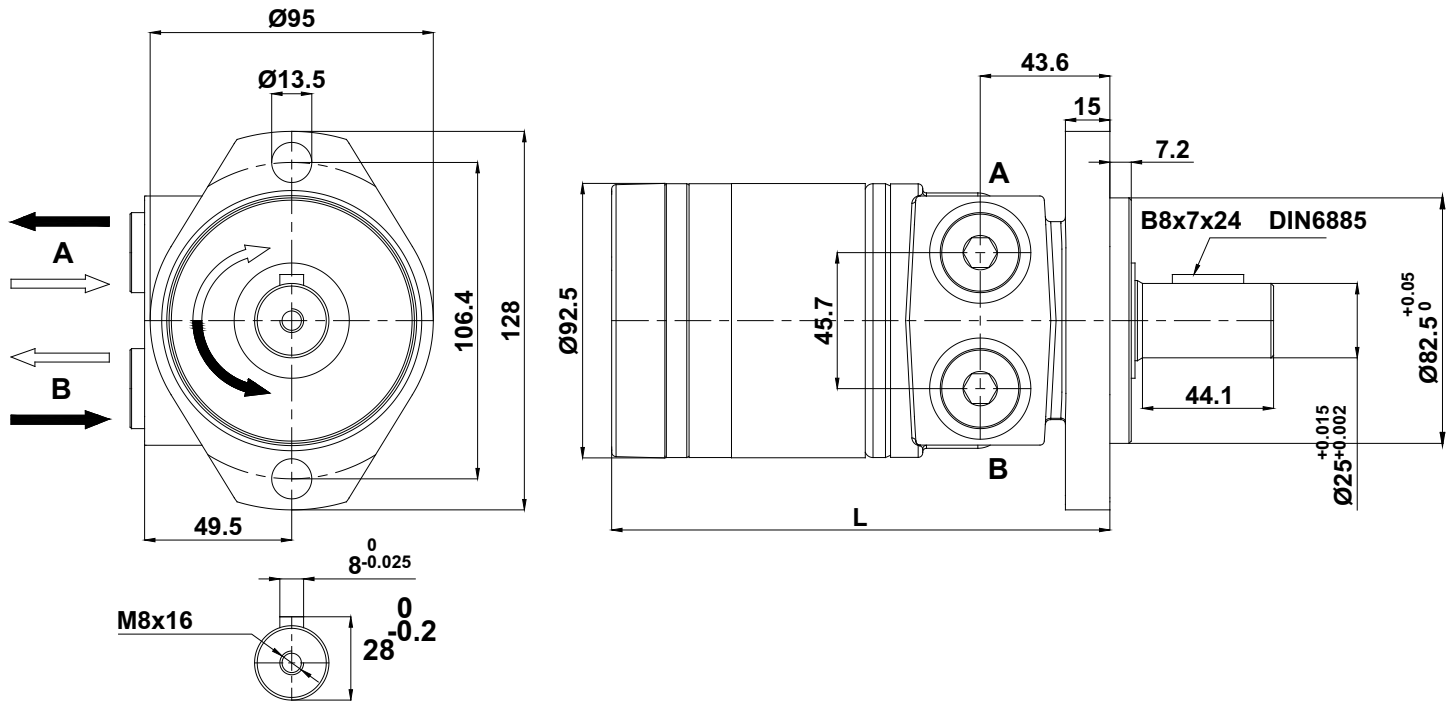

10.2 HG Series flange and Shaft dimensions:

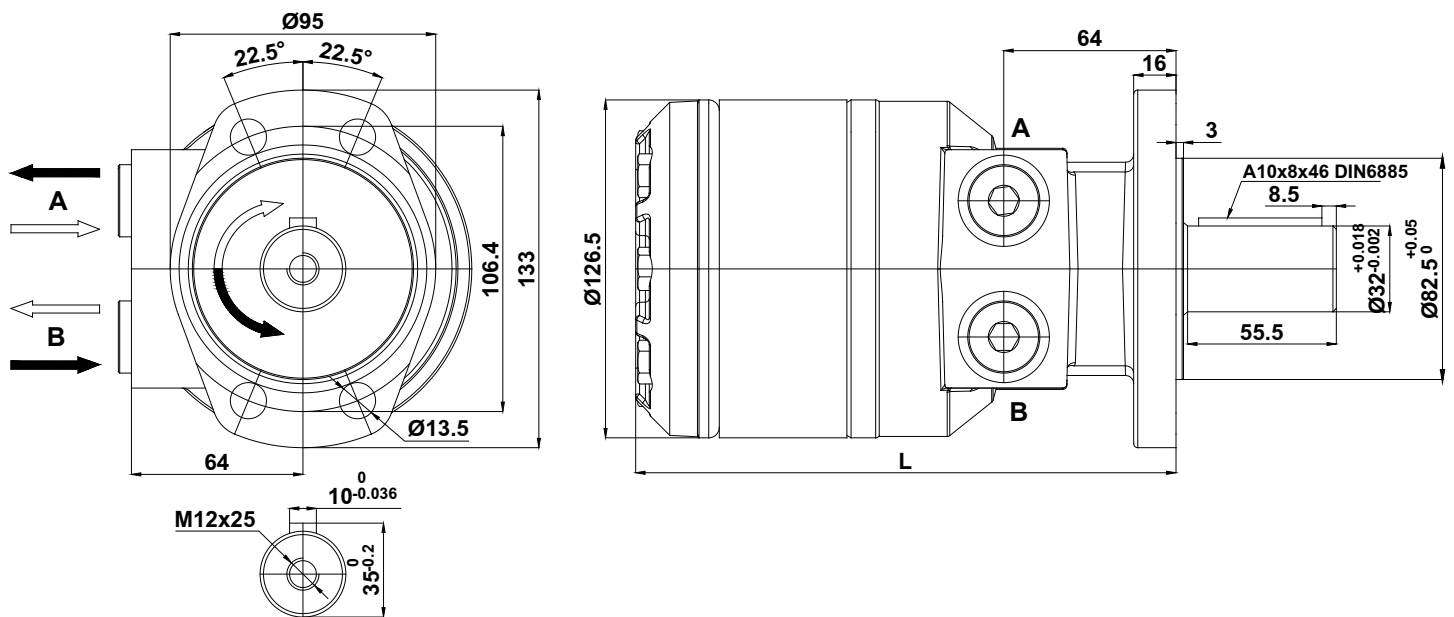



## 11- Troubleshooting Guide



All the operations bellow must be done by authorized and skilled mechanician / electrician. Inform YILMAZ REDUKTOR before making any change to the gearbox. Only oil change is allowed to change without information. Do not make anything if you are not sure what you are doing and contact YILMAZ. Any change or operation done without the information of YILMAZ REDUKTOR is in your own risk and responsibility and YILMAZ REDUKTOR does not take any responsibility.

ID	Problem	Observation	Remedy
001	Gearbox Does Not Start Up	You hear no noise and shaft is not turning. You are not using any driver or frequency inverter.	Please Check the voltage supply and frequency of your electric connection. They must be in accordance with the nameplate of the motor. Observe motor manufacturers start up manual. Still does not work go to ID 100
002	Gearbox Does Not Start Up	You hear no noise and shaft is not turning. You are using frequency inverter or driver.	Please observe the frequency inverter/driver manual. Check the motor by supplying direct voltage to see if the problem is on your driver/frequency inverter. Still does not work go to ID 001.
003	Gearbox Does Not Start Up	You hear some noise but both motor shaft and gearbox shaft is not turning. You are not using any driver / frequency inverter or braked motor.	Please Check the voltage supply and frequency of your electric connection. They must be in accordance with the nameplate of the motor. Observe motor manufacturers start up manual. Still same problem, the load may be too high for the chosen motor. Loosen the gearbox from the load/torque. If it works than the starting torque is insufficient and higher motor power is needed. For monophaze motors, check the starting up compensator and running condensate as well. If nothing helps go to ID 100
004	Gearbox Does Not Start Up	You hear some noise but both motor shaft and gearbox shaft is not turning. You are using driver or frequency inverter.	Please observe the frequency inverters or drivers manual. To see if the problem is on your driver or frequency inverter take out the driver/frequency inverter and make direct voltage supply to the motor according the motors nameplate. Still does not work go to ID 100
005	Gearbox Does Not Start Up	You hear some noise but both motor shaft and gearbox shaft is not turning. You are using braked motor	Please Check the voltage supply and frequency of your electric connection. They must be in accordance with the nameplate of the motor. Observe motor manufacturers start up manual. Be sure that the brake is working. Observe the brake manufacturers manual. If brake is supplied from YILMAZ observe this manual for correct brake wiring diagram. If still not work supply the brake with voltage according its nameplate directly. For example 198V DC. You will hear a clicking noise explaining that the brake is opening. If you hear no noise the brake or rectifier is defect. If you hear the clicking noise the brake is working. You should this clicking noise by your normal electric connection as well. By supplying direct supply to the brake you hear the clicking noise and at same time you supply the motor with direct voltage according to its name plate and still same problem, the load may be too high for the chosen motor. Go to ID 003.

# Operating Instructions

## P/R Series

### Troubleshooting Guide



ID	Problem	Observation	Remedy
006	Gearbox Does Not Work in Low Speeds/frequencies.	You are using frequency inverter.	For very low speeds the frequency inverters frequency is lowering down. For very low frequencies the inverter parameter and motor parameter must be optimized. Also for low speeds the efficiency of the gearbox may vary too much. Specially for worm-gearboxes. The recommended frequency range is 20-70 Hz for worm-gearboxes and 10-70 Hz for Helical Gear Boxes. Use Higher motor power and Frequency inverter or change ratio of gearbox to work inside the recommended range.
007	Gearbox Does Not Start Mornings or After Long Time Stop.	Ambient Temperature is below +5 Celsius	The oil is not in accordance with your working conditions. Change to lower viscosity oils. Observe this manual for using the correct oil. Working in higher ambient temperatures is an other solution if possible. If still same problem you need higher motor power.
008	Gearbox Heating is Up too Much	You are using Worm Gear Box and ambient temp is lower than +40 Celsius	Measure the surface temp. using a temperature measuring device under full load. If the temp is under +80 Celsius this will make no harm to the gearbox and is normal. All ATEX conforming gearboxes and standard worm gearboxes are designed to work under max. +120 Celsius. <u>If higher than +120 Celsius and using ATEX conforming gear box immediately stop the system and contact YILMAZ REDUKTOR.</u> Go to ID 100. If not ATEX confirming check the oil type and oil quantity/level according your mounting position and check the nameplate mounting position. If nameplate mounting position does not fit the actual position go to ID 100.
009	Gearbox Heating is Up too Much	You are using Helical Gear Box. Ambient temp is lower than +40 Celsius	Measure the surface temp. using a temperature measuring device under full load. If the temp is under +80 Celsius this will make no harm to the gearbox and is normal. All ATEX conforming gearboxes are designed to work under max. +120 Celsius. <u>If higher than +120 Celsius and using ATEX conforming gear box immediately stop the system and contact YILMAZ REDUKTOR.</u> If not ATEX gearbox the gearbox is designed to work under max. +80 Celsius. If higher than +80 Celsius check the oil type and oil quantity/level according your mounting position and check the nameplate mounting position. If nameplate mounting position does not fit the actual position go to ID 100
010	Gearbox Heating is Up too Much	Ambient Temp is over +40 Celsius	Standard Gearboxes are designed to work under +40 Celsius. ambient temperature. If ambient temp is higher than +40 Celsius special solutions/gearboxes are required. Please contact YILMAZ
011	Gearbox is noisy	Nois is regular continuous	Check Your moving parts for noise. Disassemble the gearbox and run without load. If you still hear the noise motor bearings or gearbox bearings are defect. Change bearings. Go to ID 100
012	Gearbox is noisy	Nois is random	Check Your moving parts for noise. Disassemble the gearbox and run without load. If you hear still the noise the oil may has some particles inside. Change the oil and look for small particles. If metal particles are found the gearbox may have some damage. Go to ID 100

# Operating Instructions

## P/R Series

### Troubleshooting Guide



ID	Problem	Observation	Remedy
013	Gearbox is noisy	Regular knocking noise	Check Your moving parts for noise. Disassemble the gearbox and run without load. If you still hear the noise one of the gears inside is defect. Go to ID 100
014	Gearbox is noisy	Regular up and down noise	Check the output-shaft connection elements for run out. Take out the output shaft element and run without load. If you still hear the noise one of the gears has run out problem. Go to ID 100
015	Gearbox is noisy	Gearbox is with braked motor and noise is coming from the brake side randomly.	Low randomly clicking noise may come from the brake disc which is normal. If noise level is disturbing the brake may be defect or brake clearance is not adjusted. Go to ID 100
016	Gearbox is noisy	You are using frequency inverter and the noise level is changing according your speed.	The frequency inverter parameters are not optimized for the frequency range or motor you are using. Observe the frequency inverters manual. If still same problem change the ratio of gearbox. Go to ID 100
017	Oil is Leaking	Oil Leakage from Seal	If ambient Temp is over +40 Celsius or none stop work over 16 hours please change the top plug with a breather plug. Observe this manual for using breather plug. If this is not your case the seal could be damaged. Go to ID 100
018	Oil is Leaking	Oil Leakage from Plug	If you are using breather plug be sure it is in the correct place. This is the most top plug position according your mounting position. The plug may be not tight enough. There are some particles under the plug rubber surface. Clean and tighten the plug. If still same problem go to ID 100
019	Oil is Leaking	Oil Leakage from Housing	Observe exactly where the oil is coming out. It could be seal or plug point where it comes out and leaks over the housing. If this is your case goto ID 018/019. If you are sure oil comes out from housing than housing has some micro split / crack. Go to ID 100
020	Oil is Leaking	Oil Leakage from Cover	The sealing liquid under cover is split/defect. Disassemble the cover and put new sealing liquid. Assemble the cover and tighten the bolts. If still same problem go to ID 100
021	Gearbox is moving regularly on its mounting point	You are using Torque Arm	The movement of gear box is because of the run out of the shaft which you assemble the gearbox. This has no bad affect or harm to the gearbox and is normal unless you are using torque arm.
022	Gearbox is moving randomly on its mounting point	You are using Torque Arm	The movement of gear box is because of the run out and clearance of the shaft which you assemble the gearbox. Check the clearance of the assembling shaft and the clearances on your machine. This has no bad affect or harm to the gearbox unless you are using torque arm.
023	Motor is heating up	Motor is running over its nominal current	The motor power is not enough or some overload to the motor is possible. The motor may be defect. Go to ID 100
023	Motor is heating up	Ambient is dusty	Check the motor Fan Hub and ribs. They must be free of dust. If you are using forced external fan, check if it is working. If you are using frequency inverter in low speeds and you do not have forced external fan, you may need forced external fan. Go to ID 100



ID	Problem	Observation	Remedy
024	Motor is running but Gear-box shaft does not turn	Scratching noise comes out	Some part (key, gear) may be defect inside gearbox. Go to ID 10
025	Gearbox Housing is Defect	You are using chain drive or pinion gear	The radial load or polygon effect of the chain may have caused the damage. Check also if the assembly bolts are loosened or the plate you assemble the gearbox is rigid enough. Check if you are using the correct diameter of chain drive and you are not exceeding max. Allowed radial load. Check the position of your output element and re-calculate your radial load and check if this fit to the maximum allowed radial load. Go to ID 100
026	Output Shaft is Defect	You are using chain drive or pinion gear	The radial load or polygon effect of the chain may have caused the damage. Check also if the assembly bolts are loosened or the plate you assemble the gearbox is rigid enough. Check if you are using the correct diameter of chain drive and you are not exceeding max. allowed radial load. Check the position of your output element and re-calculate your overhung load and check if this fit to the maximum allowed load. Go to ID 100
027	Gearbox is stopping too late	You are using braked motor	Please check the wiring diagram of the brake. There are two different kind of brake wiring diagram. The standard gearbox delivered from our factory is set to delayed braking. For sudden braking check the wiring diagram.
028	Gearbox is starting too late	You are using braked motor	For fast opening of big brakes (over 100Nm), you may need shock transformers which is supplied by YILMAZ. Go to ID 100
100	Service Required	No self solution found	Please contact YILMAZ REDUKTOR Service point. See on the back side of this manual. Changing mechanical parts of gearbox can only be done by YILMAZ REDUKTOR or with information of YILMAZ REDUKTOR. Any change without informing YILMAZ REDUKTOR will cancel the warranty, manufacturer declaration and YILMAZ REDUKTOR will take no responsibility.

## 12- Disposal

If your product is no longer of use and you wish to dispose of it, refer to the instructions here. If you have any questions regarding ecological disposal methods, please consult our service points given on the backside of this Manuel.

### 12.1- Disposal of Oil

Lubricants (oil and greases) are hazardous substances, which can contaminate soil and water. Collect drained lubricant into suitable receptacles and dispose of it according to the valid national guidelines.

### 12.2- Disposal of Sealings

Remove the sealing rings from the gear reducer, and clean them of oil and grease residues. Dispose of the sealing as composite material (metal/plastic)

### 12.3- Disposal of Metal

Divide up the remainder of the gear reducer into iron, aluminium, non-ferrous heavy metal if possible. Dispose of it according to the valid national guidelines.

# Appendix





## **Warranty Conditions:**

1. The geared motors and gear units are warranted for two year except the electric motor. For motor warranty please refer to the manual of the electric motor manufacturer or the warranty document of the motor manufacturer. This warranty is valid only if the gearbox is assembled and started up according our operating instructions and is used under the allowed conditions for the appropriate gearbox type in our catalogue. Special Gearbox parts made according customer request are not covered by this warranty.
2. The warranty time starts from the start up time written on the warranty document and last for two years. If the start-up time is more then three months after the billing time, the total warranty time is limited to 27 months starting from billing time. If the warranty document is not send to our company after start-up, the total warranty time will be limited to 24 months after the billing time.
3. Any time during the warranty for maintenance, repair or change will be added to the warranty time. This time starts from the date which the company or representative was made aware of the problem and ends on the date of the re-start-up.
4. If the product fails to operate because of a manufacturing or assembly failure during the warranty time, the product will be repaired free of charge.
5. If the product fails to operate because of a manufacturing or assembly failure during the warranty time and it is not possible to repair it, the product will be changed with a new one according to the report from our service department mentioning that the hazard can not be repaired.
6. Costumers must inform the manufacturer if there are some problems after the service and repair of the failed product.
7. The extra costs like stopped plant, physical or mental injuries etc. by the costumer side are not covered by this warranty except the product itself.

### **YILMAZ REDÜKTÖR San. ve Tic. A.S.**

ATATÜRK Mah. Lozan Cad. No:17 P.K.:34522 Esenyurt-İstanbul-TÜRKİYE

Telefon: +90 (0) 212 886 90 01 (8 Hat) , Faks: +90 (0) 212 886 54 57



## **Warranty Declaration and Instruction Manual Receipt Form**

YILMAZ REDUKTOR products are **warranted for 2 (Two) years** covering all parts and materials used in products and their production errors unless they are started-up and used according our service manual and is not modified or disassembled without an acknowledgement from our company.

The warranty covers all costs like repair, service, spare parts etc. and no charge will be asked under any name. The time for repair, service will be added to the warranty time.

For detailed warranty conditions please refer the back side of this page.

**Serial No:**

**Type:**

**Manufacturer:**

Company : YILMAZ REDUKTOR Sanayi ve Ticaret A.S.

Address : ATATÜRK Mah. Lozan Cad. No:17 P.K.34522 Esenyurt-İstanbul- TÜRKİYE

Telefon : +90 (0) 212 886 90 01 (8 line)

Fax : +90 (0) 212 886 54 57

**Stamp and Signature**

**Supplier / End User:**

With signing this part and sending this back to our company your warranty period will be started and you are accepting that you have received the operating instruction of the product.

Name:

Billing Date/ Bill No.:

Start-Up Place / Date:

Address:

Phone - Fax:

**Supplier/ End User Stamp and Signature**

# Notes

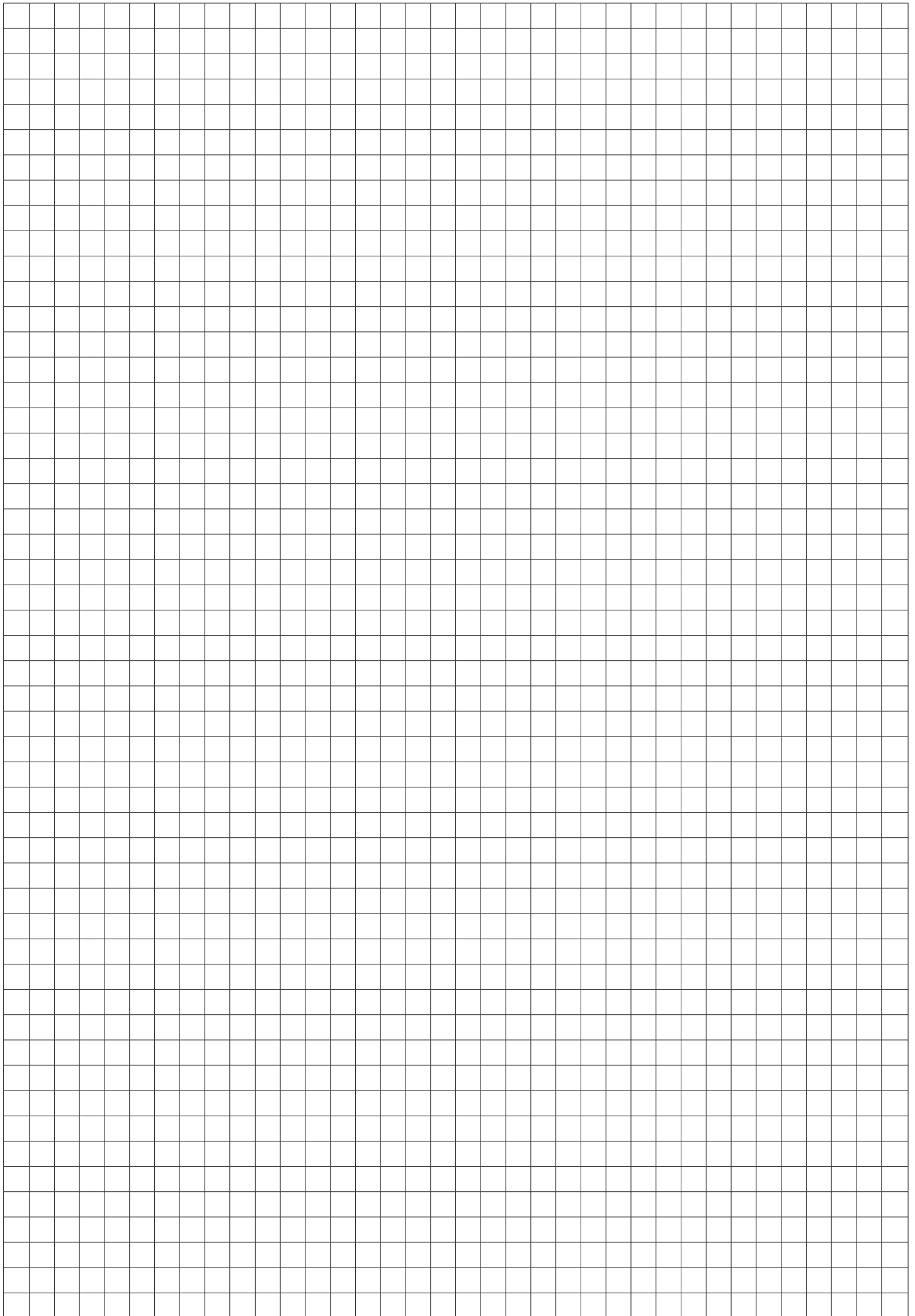



## Domestic Service

Tel: +90 212 886 90 00

Int: 1223, 1228, 1287

E-Mail: servis@yr.com.tr

## Spare Parts

Tel: +90 212 886 90 00

Int: 1224, 1277

E-Mail: yedekparca@yr.com.tr

## International Services

If you call the above service point, you will be directed to our nearest service.

---

## Yılmaz Redüktör Sanayi ve Ticaret A.Ş.

Atatürk Mah. Lozan Cad. No: 17, 34522 Esenyurt - İstanbul / Turkey

Tel: +90 212 886 90 00 | Fax: +90 212 886 54 57 | E-Mail: yilmaz@yr.com.tr